

HERON CREEK LOT 2
OR 977 P 483
OR 1085 P 92

BARNES MEGAN ELIZABETH/BARNES TIMOTHY JAMES
196 CASSEAUX RD
CRAWFORDVILLE, FL 32327

2024

00-00-037-374-09728-I.02

BUILDING CHARACTERISTICS		CONSTRUCTION	
ELEMENT	CD		
Foundation	02	CONCR	SLAB 100
Frame	02	WOOD	FRAME 100
Exterior Wall	05	HARDIE	BRD 90
Exterior Wall	19	COMMON	BRK 10
Roof Structur	03	GABLE/HIP	100
Roof Cover	03	COMP	SHNGL 100
Interior Wall	05	DRYWALL	100
Interior Floo	12	HARDWOOD	70
Interior Floo	14	CARPET	30
Heating Type	03	FORCED AIR	100
Air Condition	03	CENTRAL	100
Bedrooms		4	100
Bathrooms		3	100
Story Height		0	100
Stories	1.	1.	100
Units		0	100
Quality	03	AVERAGE	
DOR CODE	5000	IMPRVD AG RES	
MAP NUM	1	MKT AREA	10
NEIGHBORHOOD/LOC	000	1.00/	
AREA TYPE	TOTAL GROSS AREA	PCT OF BASE	YEAR
TOTALS	4,402	3,255	349,422

MARKET ADJUSTMENTS													
TYPE	MDL	EFF. AREA	TOT ADJ PTS	EFF. BASE RATE	REPL. COST NEW	AYB	EYB	ECON	FNCT	NORM	% COND		
0100	01	3,255	115.3000	109.54	356,553	2021	2021	0	0	2.00	98.00		
1 SINGLE FAM 100% - 2022 Heated Area: 2736 HX Base Yr 2022													

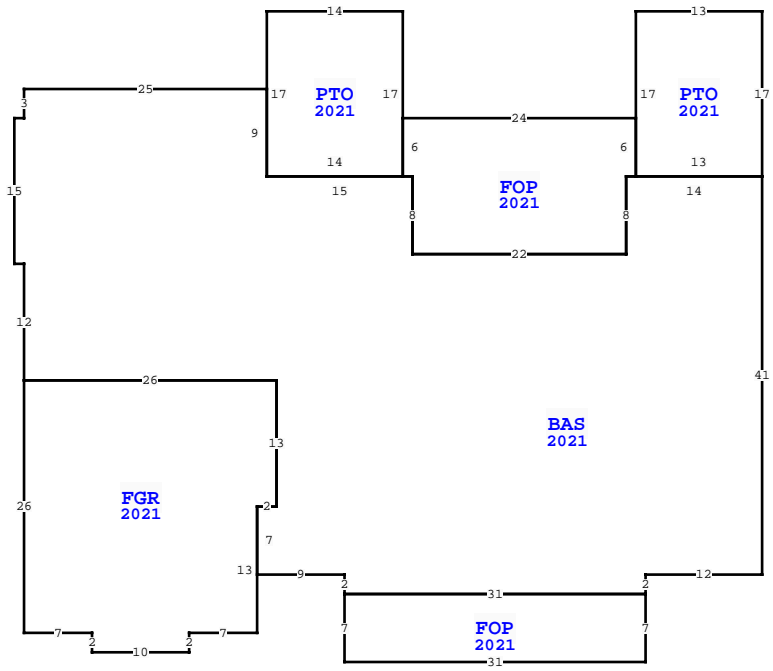

WAKULLA COUNTY PROPERTY			
VALUATION SUMMARY			PAGE 1 of 1
VALUATION BY		STANDARD	
Tax Group: 3		Tax Dist:	
BUILDING MARKET VALUE		349,422	
TOTAL MARKET OB/XF VALUE		10,680	
TOTAL LAND VALUE - MARKET		82,725	
TOTAL MARKET VALUE		378,036	
SOH/AGL Deduction		0	
ASSESSED VALUE		378,036	
TOTAL EXEMPTION VALUE		HX HB 50,000	
BASE TAXABLE VALUE		328,036	
TOTAL JUST VALUE		442,827	
NCON VALUE		0	
INCOME VALUE		0	
PREVIOUS YEAR MKT VALUE		379,068	
2022 AG RENEWAL RCD			
2022 HX APP			
ADDRESS CHANGE PER TJB REQUEST			
PU NEW SFD; XFOB'S CO 9-22-2021 MMLB			
PERMIT NUM	DESCRIPTION	AMT	ISSUED
B24-000571	IN-GROUND POOL		07/08/2024
21000050	SFD-CO	0	02/11/2021

SALES DATA						
OFF RECORD Number	DATE	TYPE INST	Q U	V I	RSN CD	SALE PRICE
1085/0092	9/06/2018	WD Q	Q	V	01	73,000
GRANTOR: TABOR ELIZBETH LANE &						
GRANTEE: BARNES MEGAN ELIZAB						
0977/0483	8/04/2015	WD U	V	12		45,000
GRANTOR: CAPITAL CITY BANK						
GRANTEE: TABOR ELIZABETH LAN						

EXTRA FEATURES																
L N	OB/XF CODE	DESCRIPTION	BLD CAP	L	W	UNITS	UT	Adj R	ADJ UNIT PRICE	ORIG COND	YEAR ON	YEAR ACTUAL	Q	% COND	OB/XF MKT VALUE	NOTES
1	0140	FIRE PLACE	0	100	0	1.00	UT	1,900.00	1,900.00	100	2021	2021	3	96	1,824	
2	0210	CONCRETE D	0	100	45	25	SF	6.00	6.00	100	2021	2021	3	93	6,278	
3	0210	CONCRETE D	0	100	22	9	SF	6.00	6.00	100	2021	2021	3	93	1,105	
4	0211	CONCRETE W	0	100	66	4	SF	6.00	6.00	100	2021	2021	3	93	1,473	

TOTAL OB/XF													
10,680													

BUILDING NOTES													
PTO=[YR=2021] W13 S17 E13 BAS=[YR=2021] W14 S8 W22													
FOP=[YR=2021] E22 N8 E1 N6 W24 S6 E1 S8\$ N8 W15 PTO=[YR=2021] E14 N17 W14 S17\$ N9 W25 S3 W1 S15 E1 S12 E26 FGR=[YR=2021] W26 S26 E7 S2 E10 N2 E7 N13 E2 N13\$ S13 W2 S7 E9 S2 E31													
FOP=[YR=2021] W31 S7 E31 N7\$ N2 E12 N41\$ N17\$.													

LAND DESCRIPTION																								
L N	USE CODE	CLS	LAND USE DESCRIPTION	CAP	R D	LOC ZONE	FRONT	DEPTH	TOT LND UTS	UNIT TYPE	D T	DPHT FACT	% COND	TOT ADJ	UNIT PRICE	ADJ UNIT PRICE	LAND VALUE	OTHER ADJUSTMENTS AND NOTES	YEAR	DENSITY	DECL	FRZ	YR	CONSRV
1	000110	C	SFR RURAL	100			0.00	0.00	1.00	AC		1.00	1.00	1.00	15,000.00	15,000.00	15,000							
2	006100	A	PASTURE 2	0			0.00	0.00	5.65	AC		1.00	1.00	1.00	325.00	325.00	1,836							
3	005970	A	TIMBER MIX 1	0			0.00	0.00	3.38	AC		1.00	1.00	1.00	325.00	325.00	1,098							