

LYING IN THE NW1/4 OF
 HS LOT 41 P-1-67-M-10
 OR 169 P 305 OR 470 P 607

WILKINS DARYN
 649 TURNEY ANDERSON RD
 MONTICELLO FL, FL 32344

2024

00-00-041-000-09778-067



ELEMENT		CD		CONSTRUCTION	
Foundation	01	WOOD	FRAME	100	
Frame	02	WOOD	FRAME	100	
Exterior Wall	08	WD	ON PLY	100	
Roof Structur	03	GABLE/HIP	100		
Roof Cover	01	MINIMUM	100		
Interior Wall	05	DRYWALL	100		
Interior Floor	09	PINE WOOD	90		
Interior Floor	02	MIN PLYWD	100		
Heating Type	04	AIR DUCTED	100		
Air Condition	03	CENTRAL	100		
Bedrooms		2	100		
Bathrooms		2	100		
Story Height		0	100		
Stories	1.5	1.5	100		
Units		0	100		
Quality	08	FAIR			
DOR CODE	0100	SINGLE FAMILY			
MAP NUM	4	MKT AREA	10		
NEIGHBORHOOD/LOC	999.00	1.25/			
AREA TYPE	TOTAL GROSS AREA	PCT OF BASE	YEAR	TOT ADJ AREA	SUBAREA MARKET VALUE
BAS	672	100	1993	672	53,420
BAS	110	100	2003	110	8,744
DCK	24	10	2003	2	159
DCK	80	10	2003	8	636
DSR	96	55	2003	53	4,213
FSP	150	55	1993	82	6,518
FUS	288	100	1993	288	22,894
UOP	96	20	1993	19	1,510
UOP	96	20	1993	19	1,510
TOTALS	1,612			1,253	99,607

MARKET ADJUSTMENTS											
TYPE	MDL	EFF. AREA	TOT ADJ PTS	EFF. BASE RATE	REPL. COST NEW	AYB	EYB	ECON	FNCT	NORM	% COND
1	SINGLE FAM	100% - 2019			144,358	1992	1992	0	0	31.00	69.00
Heated Area: 1070						HX Base Yr 2019					

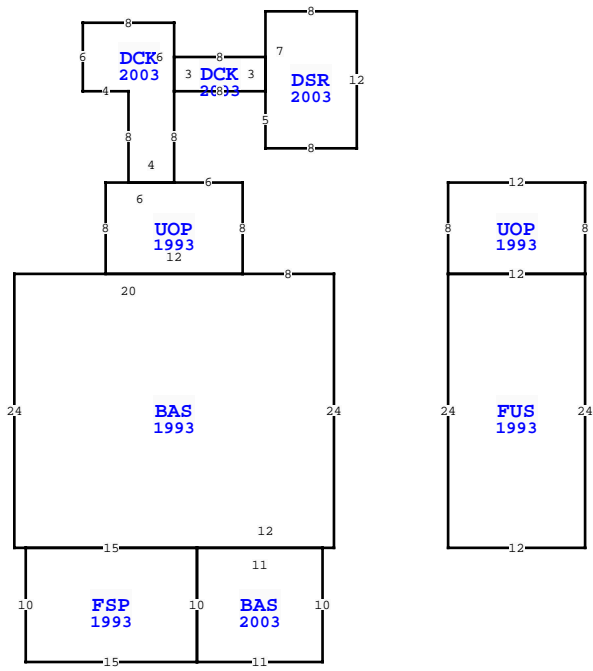

WAKULLA COUNTY PROPERTY				PAGE 1 of 2	3	
VALUATION SUMMARY						
VALUATION BY				STANDARD		
Tax Group: 3		Tax Dist:				
BUILDING MARKET VALUE				99,607		
TOTAL MARKET OB/XF VALUE				9,837		
TOTAL LAND VALUE - MARKET				37,500		
TOTAL MARKET VALUE				146,944		
SOH/AGL Deduction				53,101		
ASSESSED VALUE				93,843		
TOTAL EXEMPTION VALUE				50,000		
BASE TAXABLE VALUE				43,843		
TOTAL JUST VALUE				146,944		
NCON VALUE				0		
INCOME VALUE						
PREVIOUS YEAR MKT VALUE				131,994		
H5 DUE TO COA PER NCOA REPORT						
DELETE FUNC, PU XFOB LN-1 CARD-3						
ADD HX FOR 2019-WILKINS						
EMAILED DR501R TO WALTON FOR NUGEN						
PERMIT NUM	DESCRIPTION	AMT	ISSUED			
20000230	SOLAR PANELS-CO	0	11/23/2020			
17000701	WATER HEATER	0	05/23/2017			
16001219	SAFETY INSP	0	12/05/2016			
16000935	SAFETY INSP	0	09/21/2016			
SALES DATA						
OFF RECORD Number	DATE	TYPE INST	Q U	V I	RSN CD	SALE PRICE
1076/0494	6/12/2018	WD Q	I	01		97,000
GRANTOR: NUGEN SAMUEL & INES						
GRANTEE: WILKINS DARYN						
1009/0819	8/23/2016	WD U	I	12		53,600
GRANTOR: DEUTSCHE BANK NATIONA						
GRANTEE: NUGEN SAMUEL & INES						

EXTRA FEATURES																
L N	OB/XF CODE	DESCRIPTION	BLD CAP	L	W	UNITS	UT	Adj R	ADJ UNIT PRICE	ORIG COND	YEAR ON	YEAR ACTUAL	Q	% COND	OB/XF MKT VALUE	NOTES
1	0940	OPEN SHED	0	100	12	18			4.00	100	1993	1993	3	20	173	
2	0620	WOOD UTL B	0	100	18	40			6.00	100	1993	1993	3	20	864	
3	0130	FIRE PLACE	0	100	0	0			1,300.00	100	1992	1992	3	49	637	
4	0700	PORT BLDG	0	100	8	10			8.00	100	2003	2003	3	60	384	
5	0955	PRIVACY FE	0	100	0	0			15.00	100	2003	2003	3	0	0	
6	0050	CARPORT UN	0	100	11	17			9.00	100	2003	2003	3	60	1,010	
7	0050	CARPORT UN	0	100	16	19			9.00	100	2003	2003	3	60	1,642	
8	0050	CARPORT UN	0	100	9	18			9.00	100	2003	2003	3	60	875	
9	0213	CONCRETE P	0	100	32	21			6.00	100	2003	2003	3	100	4,032	
10	0950	METAL SHED	0	100	11	6			8.00	100	2003	2003	3	21	111	

TOTAL OB/XF												9,728												
L N	USE CODE	CLS	LAND USE DESCRIPTION	CAP	R D	LOC ZONE	FRONT	DEPTH	TOT LND UTS	UNIT TYPE	D T	DPH FACT	% COND	TOT ADJ	UNIT PRICE	ADJ UNIT PRICE	LAND VALUE	OTHER ADJUSTMENTS AND NOTES	YEAR	DENSITY	DECL	FRZ	YR	CONSRV
1	000100	C	SFR	100		RR1	0.00	0.00	2.50	AC		1.00	1.00	1.00	15,000.00	15,000.00	37,500							

LAND DESCRIPTION																								
1	000100	C	SFR	100		RR1	0.00	0.00	2.50	AC		1.00	1.00	1.00	15,000.00	15,000.00	37,500							

TOTAL OB/XF												9,728												
1	000100	C	SFR	100		RR1	0.00	0.00	2.50	AC		1.00	1.00	1.00	15,000.00	15,000.00	37,500							

BUILDING NOTES											
BAS=[YR=1993] W8 UOP=[YR=1993] N8 W6 DCK=[YR=2003] N8 DCK=[YR=2003] E8 DSR=[YR=2003] S5 E8 N12 W8 S7\$ N3 W8 S3\$ N6 W8 S6 E4 S8 E4\$ W6 S8 E12\$ W20 S24 E1 FSP=[YR=1993] S10 E15 N10 W15 \$ E15 BAS=[YR=2003] S10 E11 N10 W11\$ E12 N24\$ PTR=E10 FUS=[YR=1993] S24 E12 N24 UOP=[YR=1993] N8 W12 S8 E12\$ W12\$ W10\$.											
BUILDING DIMENSIONS											

