

EASTGATE SUBDV LOT 47
 OR 534 P 397 OR 534 P 399
 OR 592 P 713

BROGDON TRAVIS P
 21 EASTGATE WAY
 CRAWFORDVILLE, FL 32327

2024

00-00-059-300-10035-A47

ELEMENT		CD	CONSTRUCTION
Foundation	02	CONCR	SLAB 100
Frame	02	WOOD	FRAME 100
Exterior Wall	05	HARDIE BRD	100
Roof Structur	03	GABLE/HIP	100
Roof Cover	03	COMP SHNGL	100
Interior Wall	05	DRYWALL	100
Interior Floor	08	SHT VINYL	50
Interior Floor	14	CARPET	50
Heating Type	13	HEAT PUMP	100
Air Condition	13	HEAT PUMP	100
Bedrooms			3 100
Bathrooms			2 100
Story Height			0 100
Stories	1.		1. 100
Fireplace	01	FIREPLACE	100
Units			0 100
Quality	03	AVERAGE	
DOR CODE	0100	SINGLE FAMILY	
MAP NUM	3	MKT AREA	10
NEIGHBORHOOD/LOC	300.00	1.00/	
AREA TYPE	TOTAL GROSS AREA	PCT OF BASE	YEAR
BAS	1,320	100	2005
FGR	408	50	2005
FOP	132	30	2005
PTO	100	5	2005
TOTALS	1,960		

MARKET ADJUSTMENTS													
TYPE	MDL	EFF. AREA	TOT ADJ PTS	EFF. BASE RATE	REPL. COST NEW	AYB	EYB	ECON	FNCT	NORM	% COND		
1	SINGLE FAM	100%	- 2010		Heated Area: 1320					HX	Base Yr 2010		

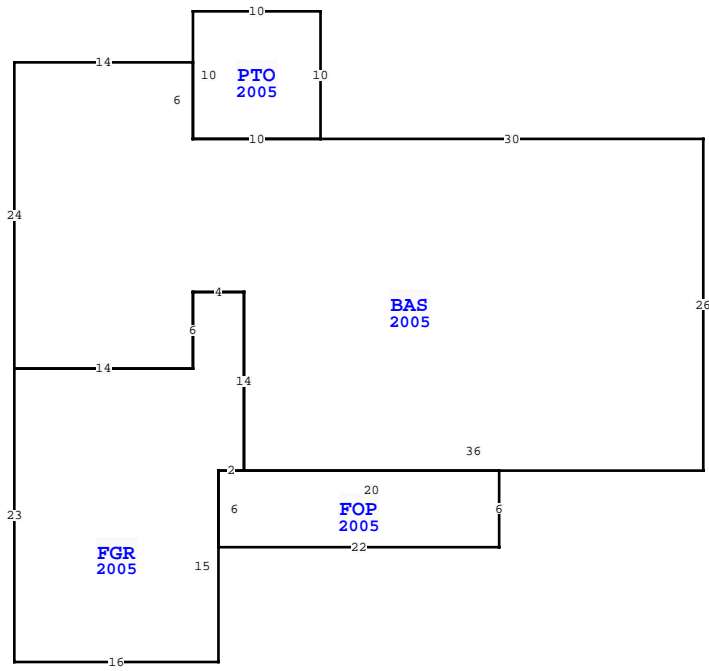

WAKULLA COUNTY PROPERTY				PAGE 1 of 1	3	
VALUATION SUMMARY						
VALUATION BY	STANDARD					
Tax Group: 3	Tax Dist:					
BUILDING MARKET VALUE	142,399					
TOTAL MARKET OB/XF VALUE	667					
TOTAL LAND VALUE - MARKET	18,000					
TOTAL MARKET VALUE	161,066					
SOH/AGL Deduction	51,524					
ASSESSED VALUE	109,542					
TOTAL EXEMPTION VALUE	50,000			HX HB		
BASE TAXABLE VALUE	59,542					
TOTAL JUST VALUE	161,066					
NCON VALUE	0					
INCOME VALUE	0					
PREVIOUS YEAR MKT VALUE	155,880					
5 YR PRCL CK, N/C						
5 YR PRCL CH, N/C						
5 YR PRCL CH, N/C						
ADD HX FOR 2010 PH#556-6572						
PERMIT NUM	DESCRIPTION	AMT	ISSUED			
2005612	SFD	0	05/03/2005			
SALES DATA						
OFF RECORD Number	DATE	TYPE INST	Q / U	V / I	RSN CD	SALE PRICE
0806/0036	9/18/2009	WD	U	I	18	120,400
GRANTOR: FANNIE MAE AKA FEDERA						
GRANTEE: BROGDON TRAVIS P						
0800/0850	7/27/2009	CT	U	I	18	100
GRANTOR: HUFFMAN LIONEL AKA LI						
GRANTEE: FANNIE MAE						
BUILDING NOTES						
BUILDING DIMENSIONS						
BAS=[YR=2005] W30 PTO=[YR=2005] N10 W10 S10 E10\$ W10 N6 W14 S24 FGR=[YR=2005] S23 E16 N15 E2 N14 W4 S6 W14\$ E14 N6 E4 S14 FOP=[YR=2005] W2 S6 E22 N6 W20\$ E36 N26\$.						

EXTRA FEATURES														21 EASTGATE WAY, CRAWFORDVILLE		
L N	OB/XF CODE	DESCRIPTION	BLD CAP	L	W	UNITS	UT	Adj R	ADJ UNIT PRICE	ORIG COND	YEAR ON	YEAR ACTUAL	Q	% COND	OB/XF MKT VALUE	NOTES
1	0210	CONCRETE D	0 100	20	20	400.00	SF	6.00	6.00	100	2005	2005	3	24	576	
2	0211	CONCRETE W	0 100	0	0	63.00	SF	6.00	6.00	100	2005	2005	3	24	91	

LAND DESCRIPTION														TOTAL OB/XF										
L N	USE CODE	CLS	LAND USE DESCRIPTION	CAP	R D	LOC ZONE	FRONT	DEPTH	TOT LND UTS	UNIT TYPE	D T	DPH FACT	% COND	TOT ADJ	UNIT PRICE	ADJ UNIT PRICE	LAND VALUE	OTHER ADJUSTMENTS AND NOTES	YEAR	DENSITY	DECL	FRZ	YR	CONSRV
1	000100	C	SFR	100			0.00	0.00	1.00	LT		1.00	1.00	1.00	18,000.00	18,000.00	18,000							