

EASTGATE SUBD LOT 50
 OR 534 P 397 OR 534 P 399
 OR 628 P 693 OR 642 P 770

LYONS JAMES CORBITT/LYONS BRITTANY MICHELE
 39 EASTGATE WAY
 CRAWFORDVILLE, FL 32327

2024

00-00-059-300-10035-A50

BUILDING CHARACTERISTICS					
ELEMENT	CD	CONSTRUCTION			
Foundation	02	CONCR SLAB 100			
Frame	02	WOOD FRAME 100			
Exterior Wall	05	HARDIE BRD 100			
Roof Structur	03	GABLE/HIP 100			
Roof Cover	03	COMP SHNGL 100			
Interior Wall	05	DRYWALL 100			
Interior Floor	08	SHT VINYL 50			
Interior Floor	14	CARPET 50			
Heating Type	13	HEAT PUMP 100			
Air Condition	13	HEAT PUMP 100			
Bedrooms		3 100			
Bathrooms		2 100			
Story Height		0 100			
Stories	1.	1. 100			
Units		0 100			
Quality	03	AVERAGE			
DOR CODE	0100	SINGLE FAMILY			
MAP NUM	3	MKT AREA 10			
NEIGHBORHOOD/LOC	300.00	1.00/			
AREA TYPE	TOTAL GROSS AREA	PCT OF BASE	YEAR	TOT ADJ AREA	SUBAREA MARKET VALUE
BAS	1,320	100	2006	1,320	125,463
FGR	408	50	2006	204	19,390
FOP	132	30	2006	40	3,802
PTO	100	5	2006	5	475
TOTALS	1,960			1,569	149,129

MARKET ADJUSTMENTS											
TYPE	MDL	EFF. AREA	TOT ADJ PTS	EFF. BASE RATE	REPL. COST NEW	AYB	EYB	ECON	FNCT	NORM	% COND
1	SINGLE FAM	100%	- 2022								
Heated Area: 1320						HX Base Yr 2022					

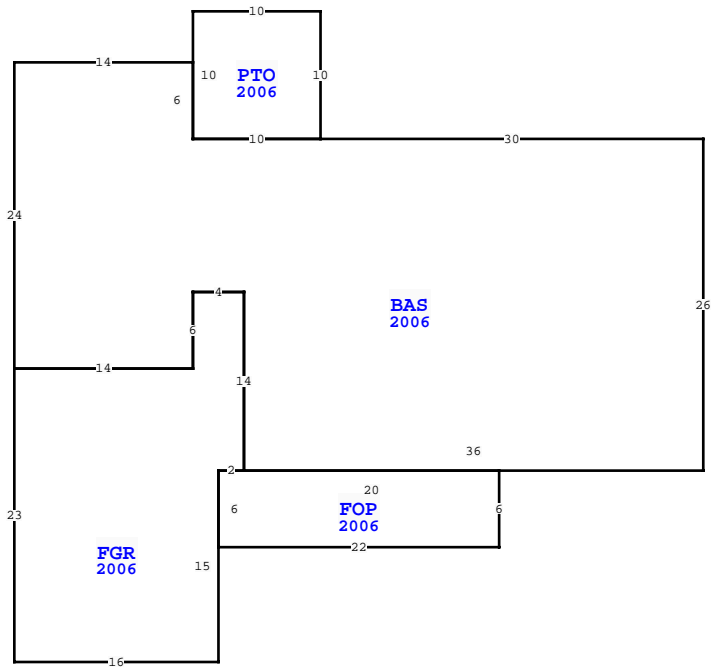

WAKULLA COUNTY PROPERTY			
VALUATION SUMMARY			PAGE 1 of 1
VALUATION BY		STANDARD	
Tax Group: 3		Tax Dist:	
BUILDING MARKET VALUE		149,129	
TOTAL MARKET OB/XF VALUE		1,965	
TOTAL LAND VALUE - MARKET		18,000	
TOTAL MARKET VALUE		169,094	
SOH/AGL Deduction		3,415	
ASSESSED VALUE		165,679	
TOTAL EXEMPTION VALUE		HX HB 50,000	
BASE TAXABLE VALUE		115,679	
TOTAL JUST VALUE		169,094	
NCON VALUE		0	
INCOME VALUE			
PREVIOUS YEAR MKT VALUE		165,030	
5 YR PRCL CK, N/C			
INCR EYB 2006-2010 PRMT OB21-000227			
5 YR PRCL CH, N/C			
FOR 2020			
PERMIT NUM	DESCRIPTION	AMT	ISSUED
21000227	RE-ROOF-CO	0	04/30/2021
20051631	SFD/CO	0	10/10/2005

SALES DATA						
OFF RECORD Number	DATE	TYPE INST	Q U	V I	RSN CD	SALE PRICE
1207/0515	5/06/2021	WD Q	Q	I	01	188,000
GRANTOR: THORNTON BARBARA HUTC						
GRANTEE: LYONS JAMES CORBITT						
1111/0715	5/30/2019	WD Q	Q	I	01	144,000
GRANTOR: HICKS SYLVIA						
GRANTEE: THORNTON BARBARA HU						

EXTRA FEATURES																
L N	OB/XF CODE	DESCRIPTION	BLD CAP	L	W	UNITS	UT	Adj R	ADJ UNIT PRICE	ORIG COND	YEAR ON	YEAR ACTUAL	Q	% COND	OB/XF MKT VALUE	NOTES
1	0210	CONCRETE D	0	100	20	20			6.00	100	2006	2006	3	27	648	
2	0211	CONCRETE W	0	100	25	3			6.00	100	2006	2006	3	27	122	
3	0955	PRIVACY FE	0	100	0	0			15.00	100	2008	2008	3	50	803	
4	0620	WOOD UTL B	0	100	12	16			6.00	100	2008	2008	3	34	392	
TOTAL OB/XF 1,965																

BUILDING NOTES														
BAS=[YR=2006] W30 PTO=[YR=2006] N10 W10 S10 E10\$ W10 N6 W14 S24 FGR=[YR=2006] S23 E16 N15 E2 N14 W4 S6 W14\$ E14 N6 E4 S14 FOP=[YR=2006] W2 S6 E22 N6 W20\$ E36 N26\$.														

LAND DESCRIPTION																								
L N	USE CODE	CLS	LAND USE DESCRIPTION	CAP	R D	LOC ZONE	FRONT	DEPTH	TOT LND UTS	UNIT TYPE	D T	DPH FACT	% COND	TOT ADJ	UNIT PRICE	ADJ UNIT PRICE	LAND VALUE	OTHER ADJUSTMENTS AND NOTES	YEAR	DENSITY	DECL	FRZ	YR	CONSRV
1	000100	C	SFR	100			0.00	0.00	1.00	LT		1.00	1.00	1.00	18,000.00	18,000.00	18,000							