

ELEMENT		CD	CONSTRUCTION
Foundation	02	CONCR	SLAB 100
Frame	02	WOOD	FRAME 100
Exterior Wall	05	HARDIE	BRD 80
Exterior Wall	19	COMMON	BRK 20
Roof Structur	03	GABLE/HIP	100
Roof Cover	03	COMP	SHNGL 100
Interior Wall	05	DRYWALL	100
Interior Floo	11	CLAY TILE	100
Heating Type	13	HEAT PUMP	100
Air Condition	13	HEAT PUMP	100
Bedrooms			3 100
Bathrooms			2 100
Story Height			0 100
Stories	1.		1. 100
Units			0 100
Quality	03	AVERAGE	
DOR CODE	0100	SINGLE FAMILY	
MAP NUM	3	MKT AREA	10
NEIGHBORHOOD/LOC	199.00	1.15/	
AREA TYPE	TOTAL GROSS AREA	PCT OF BASE	YEAR
BAS	1,703	100	1998
FEP	247	80	2000
FEP	304	80	2003
FGR	532	50	1998
FOP	30	30	1998
FSP	152	55	2003
PTO	104	5	2000
PTO	16	5	2003
PTO	160	5	2003
PTO	346	5	2024
TOTALS	4,794		

MARKET ADJUSTMENTS												
TYPE	MDL	EFF. AREA	TOT ADJ PTS	EFF. BASE RATE	REPL. COST NEW	AYB	EYB	ECON	FNCT	AP	NORM	% COND
0100	01	3,194	127.4000	139.18	444,541	1998	2000	0	0	20	23.00	57.00
1 SINGLE FAM 0% - 2024 Heated Area: 2144 HX Base Yr												

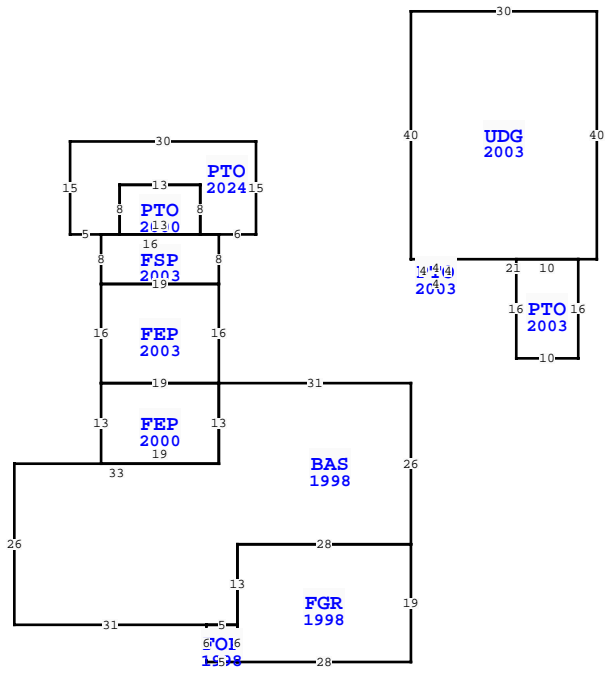

** This building has 11 Sub-Areas

BLD DATE	03/10/2017	MMSR	LGL DATE	
XF DATE	03/10/2017	MMSR	LAND DATE	03/10/2017
INC DATE			AG DATE	

WAKULLA COUNTY PROPERTY		PAGE 1 of 1	3
VALUATION BY		STANDARD	
Tax Group: 3		Tax Dist:	
BUILDING MARKET VALUE		253,388	
TOTAL MARKET OB/XF VALUE		7,943	
TOTAL LAND VALUE - MARKET		25,000	
TOTAL MARKET VALUE		286,331	
SOH/AGL Deduction		0	
ASSESSED VALUE		286,331	
TOTAL EXEMPTION VALUE		0	
BASE TAXABLE VALUE		286,331	
TOTAL JUST VALUE		286,331	
NCON VALUE		1,348	
INCOME VALUE			
PREVIOUS YEAR MKT VALUE		313,474	

PERMIT NUM	DESCRIPTION	AMT	ISSUED
19000590	REROOF-CO	0	01/03/2020
31084	GARAGE	0	12/05/2003
027167	SHED	0	11/13/2000
026796	ADD	0	07/20/2000
026084	ENCLOSURE	0	01/11/2000
023399	N/A	0	03/25/1998

SALES DATA						
OFF RECORD Number	DATE	TYPE INST	Q / U	V / I	RSN CD	SALE PRICE
1362/0725	5/20/2024	WD	Q	I	01	335,000

GRANTOR: WILLIAMS JOHN C						
GRANTEE: MATTOX JANET						
1137/0083	1/10/2020	WD	Q	I	01	215,000
GRANTOR: HERBST NANCY GAIL REN						
GRANTEE: WILLIAMS JOHN C & C						

BUILDING NOTES												
BAS=[YR=1998;ORIG=0,0] W31 S13 W33 S26 E31 E5 N13 E28 N26 \$												
UDG=[YR=2003;ORIG=0,-20] N40 E30 S40 W3 W21 W6 \$												
FGR=[YR=1998;ORIG=-28,39] S6 E28 N19 W28 S13 \$												
FEP=[YR=2003;ORIG=-31,0] N16 W19 S16 E19 \$												
FEP=[YR=2000;ORIG=-31,0] W19 S13 E19 N13 \$												
PTO=[YR=2003;ORIG=27,-20] S16 W10 N16 E10 \$												
FSP=[YR=2003;ORIG=-31,-16] N8 W3 W16 S8 E19 \$												
PTO=[YR=2000;ORIG=-34,-24] N8 W13 S8 E13 \$												
POP=[YR=1998;ORIG=-33,39] S6 E5 N6 W5 \$												
PTO=[YR=2003;ORIG=6,-20] S4 W4 N4 E4 \$												
PTR=[ORIG=0,0] N20 S20 \$												
PTO=[YR=2024;ORIG=-25,-39] W30 S15 E5 E3 N8 E13 S8 E3 E6 N15												

EXTRA FEATURES												
L N	OB/XF CODE	DESCRIPTION	BLD	CAP	L	W	UNITS	UT	Adj R	ADJ UNIT PRICE	ORIG COND	YEAR ON
1	0210	CONCRETE D	0	0	0	0	1,161.00	SF	6.00	6.00	100	1998
2	0934	PAVILION P	0	0	11	11	121.00	SF	0.00	0.00	100	2000
3	0211	CONCRETE W	0	0	0	0	234.00	SF	6.00	6.00	100	1998
4	0620	WOOD UTL B	0	0	10	12	120.00	SF	6.00	6.00	100	2000
6	0080	4' CHAINLI	0	0	0	0	363.00	LF	13.00	13.00	100	2020

LAND DESCRIPTION												
L N	USE CODE	CLS	LAND USE DESCRIPTION	CAP	R D	LOC ZONE	FRONT	DEPTH	TOT LND UTS	UNIT TYPE	DPTH FACT	% COND
1	000100	C	SFR	0			0.00	0.00	1.00	LT	1.00	1.00