

TARPINE  
BLK B LOT 11  
OR 59 P 50 & OR 67 P 480-492

ODELL CAROL  
96 MONOCOUCPE CIR  
PANACEA, FL 32346-2620

2024

01-6S-02W-147-03576-B11



ELEMENT		CD	CONSTRUCTION		
Foundation	02		CONCR	SLAB 100	
Frame	02		WOOD	FRAME 100	
Exterior Wall	08		WD ON	PLY 100	
Roof Structur	03		GABLE/HIP	100	
Roof Cover	03		COMP SHNGL	100	
Interior Wall	05		DRYWALL	100	
Interior Floor	08		SHT VINYL	50	
Interior Floor	14		CARPET	50	
Heating Type	04		AIR DUCTED	100	
Air Condition	03		CENTRAL	100	
Bedrooms			3	100	
Bathrooms			2	100	
Story Height			0	100	
Stories	1.		1.	100	
Units			0	100	
Quality	08		FAIR		
DOR CODE	0100		SINGLE FAMILY		
MAP NUM	4		MKT AREA	03	
NEIGHBORHOOD/LOC	147.00		1.00/		
AREA TYPE	TOTAL GROSS AREA	PCT OF BASE	YEAR	TOT ADJ AREA	SUBAREA MARKET VALUE
BAS	912	100	1993	912	60,070
BAS	240	100	2004	240	15,808
DCK	32	10	1993	3	197
DCK	128	10	1993	13	856
FGR	1,520	50	1993	760	50,058
TOTALS	2,832			1,928	126,989

MARKET ADJUSTMENTS													
TYPE	MDL	EFF. AREA	TOT ADJ PTS	EFF. BASE RATE	REPL. COST NEW	AYB	EYB	ECON	FNCT	NORM	% COND		
0100	01	1,928	96.3000	91.48	176,373	1991	1995		0	0	28.00	72.00	
1 SINGLE FAM 0% - 0 Heated Area: 1152 HX Base Yr													

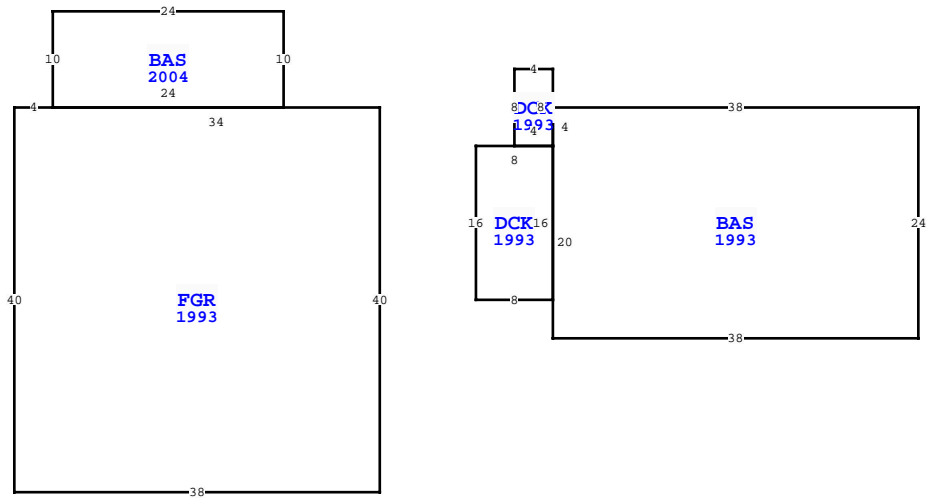

WAKULLA COUNTY PROPERTY			
VALUATION SUMMARY			PAGE 1 of 1
VALUATION BY			STANDARD
Tax Group: 3	Tax Dist:		
BUILDING MARKET VALUE			126,989
TOTAL MARKET OB/XF VALUE			3,206
TOTAL LAND VALUE - MARKET			16,500
TOTAL MARKET VALUE			146,695
SOH/AGL Deduction			0
ASSESSED VALUE			146,695
TOTAL EXEMPTION VALUE			0
BASE TAXABLE VALUE			146,695
TOTAL JUST VALUE			146,695
NCON VALUE			1,170
INCOME VALUE			
PREVIOUS YEAR MKT VALUE			145,840
MM 5YR CK, PU XF0B 2/15/23			
CORR'ED OWNER NAME AND MADE H/W			
INCR EYB 1991-1995 RE-ROOF-CC 8-2022			
5 YR PRCL CH, N/C			
PERMIT NUM	DESCRIPTION	AMT	ISSUED
22000833	RE-ROOF-CC	0	08/16/2022

SALES DATA						
OFF RECORD Number	DATE	TYPE INST	Q U	V I	RSN CD	SALE PRICE
1345/0830	2/02/2024	QC	U	I	11	100
GRANTOR: ODELL ROBERT L						
GRANTEE: ODELL CAROL						
0250/0047	2/27/1995	WD	Q	I		95,000
GRANTOR:						
GRANTEE:						

EXTRA FEATURES																
L N	OB/XF CODE	DESCRIPTION	BLD CAP	L	W	UNITS	UT	Adj R	ADJ UNIT PRICE	ORIG COND	YEAR ON	YEAR ACTUAL	Q	% COND	OB/XF MKT VALUE	NOTES
1	0130	FIRE PLACE	0	0	0	1.00	UT	1,300.00	1,300.00	100	2000	2000	3	57	741	
2	0210	CONCRETE D	0	0	69	12	SF	6.00	6.00	100	2000	2000	3	20	994	
3	0940	OPEN SHED	0	0	16	10	SF	4.00	4.00	100	2011	2011	3	47	301	
4	0210	CONCRETE D	0	0	0	0	SF	6.00	6.00	100	2024	2023	AV	100	1,170	

BUILDING NOTES													
FGR=[YR=1993] W34 BAS=[YR=2004] E24 N10 W24 S10\$ W4 S40 E38 PTR=E10 N20 DCK=[YR=1993] E8 N16 BAS=[YR=1993] S20 E38 N24 W38 S4\$ DCK=[YR=1993] N8 W4 S8 E4\$ W8 S16\$ S20 W10\$ N40\$.													

LAND DESCRIPTION														TOTAL OB/XF										
L N	USE CODE	CLS	LAND USE DESCRIPTION	CAP	R D	LOC ZONE	FRONT	DEPTH	TOT LND UTS	UNIT TYPE	D T	DPHT FACT	% COND	TOT ADJ	UNIT PRICE	ADJ UNIT PRICE	LAND VALUE	OTHER ADJUSTMENTS AND NOTES	YEAR	DENSITY	DECL	FRZ	YR	CONSRV
1	000100	C	SFR	0			0.00	0.00	1.00	LT		1.00	1.00	1.00	16,500.00	16,500.00	16,500							