

BUILDING CHARACTERISTICS		CONSTRUCTION	
ELEMENT	CD		
Foundation	03	CONCR STEM	100
Frame	30	WOOD FRAME	100
Exterior Wall	02	VINYL	100
Roof Structur	03	GABLE/HIP	100
Roof Cover	03	COMP SHNGL	100
Interior Wall	05	DRYWALL	100
Interior Floor	12	HARDWOOD	60
Interior Floor	14	CARPET	40
Heating Type	04	AIR DUCTED	100
Air Condition	03	CENTRAL	100
Bedrooms		3	100
Bathrooms		2	100
Story Height		0	100
Stories	1.5	1.5	100
Units		0	100
Quality	03	AVERAGE	
DOR CODE	5000	IMPRVD AG RES	
MAP NUM	5	MKT AREA	10
NEIGHBORHOOD/LOC	000	1.00/	
AREA TYPE	TOTAL GROSS AREA	PCT OF BASE	YEAR
BAS	2,100	100	1993
DCK	16	10	2017
FOP	20	30	1993
FOP	84	30	1993
FSP	276	55	2017
FUS	377	100	1993
TOTALS	2,873		

MARKET ADJUSTMENTS											
TYPE	MDL	EFF. AREA	TOT ADJ PTS	EFF. BASE RATE	REPL. COST NEW	AYB	EYB	ECON	FNCT	NORM	% COND
0100	01	2,662	108.8000	103.36	275,144	1990	1990	0	0	33.00	67.00
1 SINGLE FAM 100% - 0 Heated Area: 2477 HX Base Yr											

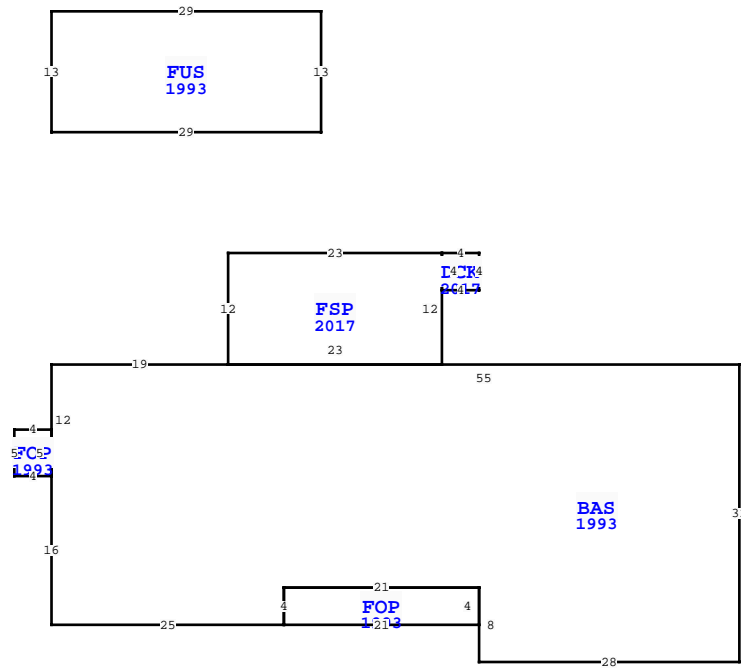

WAKULLA COUNTY PROPERTY			
VALUATION SUMMARY			PAGE 1 of 1
VALUATION BY		STANDARD	
Tax Group: 3	Tax Dist:		
BUILDING MARKET VALUE			184,346
TOTAL MARKET OB/XF VALUE			10,549
TOTAL LAND VALUE - MARKET			136,800
TOTAL MARKET VALUE			215,173
SOH/AGL Deduction			51,672
ASSESSED VALUE			163,501
TOTAL EXEMPTION VALUE	HX HB WX		55,000
BASE TAXABLE VALUE			108,501
TOTAL JUST VALUE			331,695
NCON VALUE			0
INCOME VALUE			
PREVIOUS YEAR MKT VALUE			208,683
MM 5YR CK CHG FLOORING, CHG DIMENS ON XFOB...JS KE			
2022 AG RENEWAL RECD			
2021 AG RENEWAL RECD			
ADD HX & WX FOR 2020-MCCARTHY			
PERMIT NUM	DESCRIPTION	AMT	ISSUED
18000479	REROOF-CO	0	11/28/2018
17001669	CARPORT-CO	0	11/29/2017
17000513	SCREEN ROOM	0	04/13/2017
SALES DATA			
OFF RECORD Number	DATE	TYPE INST	Q / V / RSN CD SALE PRICE
BUILDING NOTES			
BUILDING DIMENSIONS			
BAS=[YR=1993] W55 FSP=[YR=2017] E23 N12 DCK=[YR=2017] S4 E4 N4 W4\$ W23 S12\$ W19 PTR=N25 FUS=[YR=1993] E29 N13 W29 S13\$ S25\$ S12 FOP=[YR=1993] N5 W4 S5 E4\$ S16 E25 N4 E21 POP=[YR=1993] W21 S4 E21 N4\$ S8 E28 N32\$.			

EXTRA FEATURES																
L N	OB/XF CODE	DESCRIPTION	BLD CAP	L	W	UNITS	UT	Adj R	ADJ UNIT PRICE	ORIG COND	YEAR ON	YEAR ACTUAL	Q	% COND	OB/XF MKT VALUE	NOTES
1	0140	FIRE PLACE	0	100	0	1.00	UT	1,900.00	1,900.00	100	1990	1990	3	47	893	
2	0055	PORTABLE C	0	100	20	360.00	SF	3.00	3.00	100	2004	2004	3	23	248	
3	0620	WOOD UTL B	0	100	12	144.00	SF	6.00	6.00	100	2005	2005	3	24	207	
4	0940	OPEN SHED	0	100	12	84.00	SF	4.00	4.00	100	2005	2005	3	24	81	
5	0210	CONCRETE D	0	100	20	500.00	SF	6.00	6.00	100	2017	2017	3	76	2,280	
6	0210	CONCRETE D	0	100	40	1,080.00	SF	6.00	6.00	100	2017	2017	3	76	4,925	
7	0055	PORTABLE C	0	100	35	840.00	SF	3.00	3.00	100	2017	2017	3	76	1,915	

LAND DESCRIPTION												TOTAL OB/XF											
L N	USE CODE	CLS	LAND USE DESCRIPTION	CAP	R D	LOC ZONE	FRONT	DEPTH	TOT LND UTS	UNIT TYPE	DPTH FACT	% COND	TOT ADJ	UNIT PRICE	ADJ UNIT PRICE	LAND VALUE	OTHER ADJUSTMENTS AND NOTES	YEAR	DENSITY	DECL	FRZ	YR	CONSRV
1	000110	C	SFR RURAL	100			0.00	0.00	1.00	AC	1.00	1.00	1.00	15,000.00	15,000.00	15,000							
2	005970	A	TIMBER MIX 1	0			0.00	0.00	16.24	AC	1.00	1.00	1.00	325.00	325.00	5,278							