

MILL CREEK ESTATES BLOCK A  
 LOT 37 OR 49 P 184  
 OR 49 P 298 OR 60 P 566

JOHNSON TAMMIE/FISHER LISA  
 48 LESLIE ANNE ST  
 CRAWFORDVILLE, FL 32327

2024

02-4S-02W-124-01858-037



ELEMENT		CD	CONSTRUCTION
Foundation	02	CONCR	SLAB 100
Frame	02	WOOD	FRAME 100
Exterior Wall	19	COMMON	BRK 100
Roof Structur	03	GABLE/HIP	100
Roof Cover	03	COMP SHNGL	100
Interior Wall	05	DRYWALL	100
Interior Floo	07	VYL PLANK	60
Interior Floo	11	CLAY TILE	40
Heating Type	13	HEAT PUMP	100
Air Condition	13	HEAT PUMP	100
Bedrooms			3 100
Bathrooms			2 100
Story Height			0 100
Stories	1.		1. 100
Units			0 100
Quality	03	AVERAGE	
DOR CODE	0100	SINGLE FAMILY	
MAP NUM	5	MKT AREA	10
NEIGHBORHOOD/LOC	124.00	1.00/	
AREA TYPE	TOTAL GROSS AREA	PCT OF BASE	YEAR
BAS	1,486	100	1994
FGR	624	50	1994
FOP	240	30	1994
FOP	78	30	2003
FSP	260	55	1994
UDS	42	60	1994
TOTALS	2,730		

MARKET ADJUSTMENTS													
TYPE	MDL	EFF. AREA	TOT ADJ PTS	EFF. BASE RATE	REPL. COST NEW	AYB	EYB	ECON	FNCT	NORM	% COND		
1	SINGLE FAM	0%	- 2024		Heated Area: 1486		HX Base Yr						

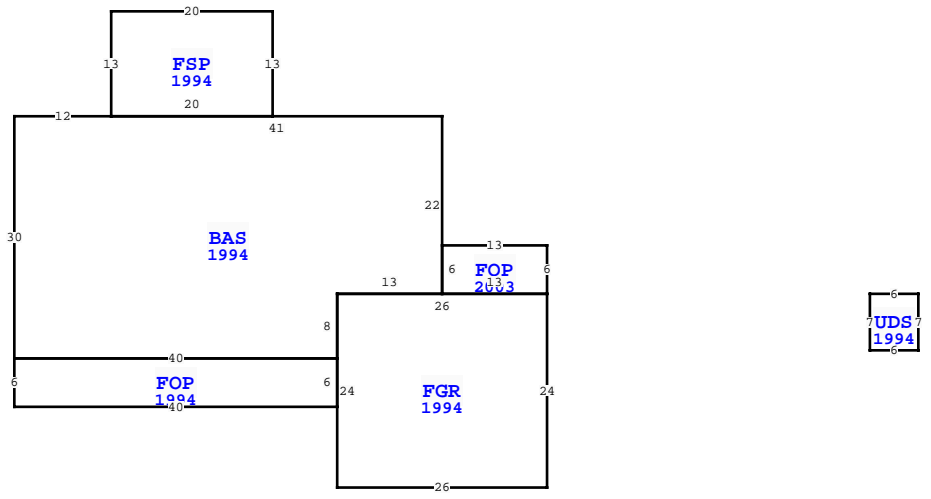

WAKULLA COUNTY PROPERTY			
VALUATION SUMMARY			PAGE 1 of 1
VALUATION BY			STANDARD
Tax Group: 3	Tax Dist:		
BUILDING MARKET VALUE			196,194
TOTAL MARKET OB/XF VALUE			2,360
TOTAL LAND VALUE - MARKET			35,500
TOTAL MARKET VALUE			234,054
SOH/AGL Deduction			0
ASSESSED VALUE			234,054
TOTAL EXEMPTION VALUE			0
BASE TAXABLE VALUE			234,054
TOTAL JUST VALUE			234,054
NCON VALUE			0
INCOME VALUE			0
PREVIOUS YEAR MKT VALUE			235,793

MM 5 YR CK, DEMO XFOB.			
CH EYB 1998-2000 PRMT OB22-000687			
2022 HX QNR RTND SENT TO ROVVIE FOR REVIEW			
INCR EYB 1994-1998 PRMT OB21-000085			
PERMIT NUM	DESCRIPTION	AMT	ISSUED
OBN24-00029	GENERATOR		06/19/2024
22000687	HVAC-CC	0	11/18/2022
21000085	RE-ROOF-CC	0	02/02/2021

SALES DATA						
OFF RECORD Number	DATE	TYPE INST	Q U	V I	RSN CD	SALE PRICE
1288/0059	10/10/2022	WD U	I	I	30	100
GRANTOR: JOHNSON TAMMIE & FISH						
GRANTEE: JOHNSON ELENA FISHE						
1288/0057	10/10/2022	WD Q	I	I	01	275,800
GRANTOR: KRAKOVEC KRISTEN						
GRANTEE: JOHNSON TAMMIE & FI						

EXTRA FEATURES																
L N	OB/XF CODE	DESCRIPTION	BLD CAP	L	W	UNITS	UT	Adj R	ADJ UNIT PRICE	ORIG COND	YEAR ON	YEAR ACTUAL	Q	% COND	OB/XF MKT VALUE	NOTES
1	0700	PORT BLDG	0	0	12	24			8.00	100	1994	1994	3	51	1,175	
2	0080	4' CHAINLI	0	0	0	0			13.00	100	2002	2002	3	20	291	
3	0210	CONCRETE D	0	0	33	22			6.00	100	2002	2002	3	20	871	
4	0211	CONCRETE W	0	0	9	2			6.00	100	2003	2003	3	21	23	

BUILDING NOTES													
75 MILL CREEK RD, CRAWFORDVILLE													
BLD DATE 09/21/2017 MMJT LGL DATE 09/21/2017 MMJT													
XF DATE 09/21/2017 MMJT LAND DATE 09/21/2017 MMJT													
INC DATE AG DATE													

BUILDING DIMENSIONS													
BAS=[YR=1994] W41 FSP=[YR=1994] E20 N13 W20 S13\$ W12 S30													
FOP=[YR=1994] S6 E40 N6 W40\$ E40 N8 FGR=[YR=1994] S24 E26 N24													
PTR=E40 UDS=[YR=1994] S7 E6 N7 W6\$ W40\$ FOP=[YR=2003] N6 W13													
S6 E13\$ W26\$ E13 N22\$.													

LAND DESCRIPTION														TOTAL OB/XF										
L N	USE CODE	CLS	LAND USE DESCRIPTION	CAP	R D	LOC ZONE	FRONT	DEPTH	TOT LND UTS	UNIT TYPE	D T	DPH FACT	% COND	TOT ADJ	UNIT PRICE	ADJ UNIT PRICE	LAND VALUE	OTHER ADJUSTMENTS AND NOTES	YEAR	DENSITY	DECL	FRZ	YR	CONSRV
1	000100	C	SFR	0			200.00	223.00	1.00	LT		1.00	1.00	1.00	35,500.00	35,500.00	35,500							