

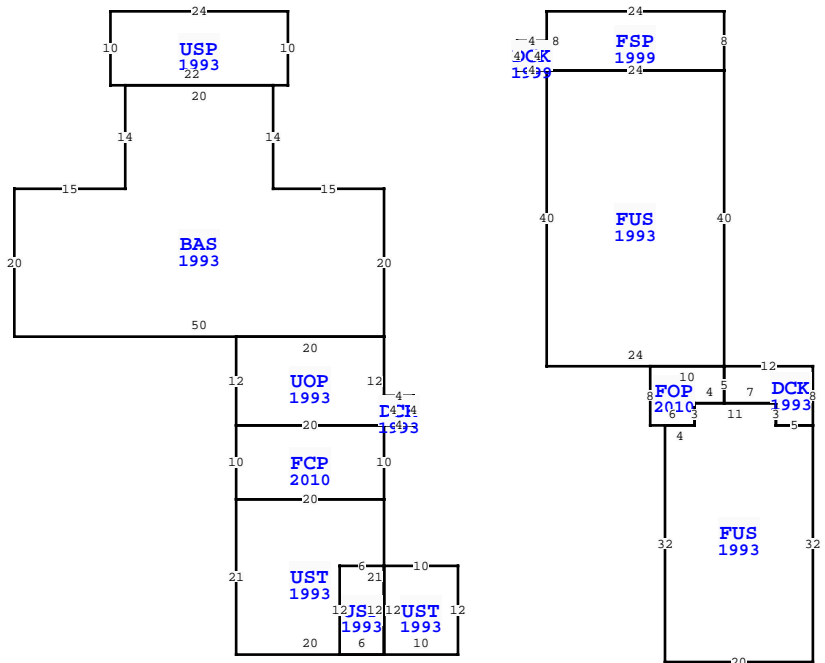

BUILDING CHARACTERISTICS		CONSTRUCTION	
ELEMENT	CD		
Foundation	02	CONCR SLAB	100
Frame	05	WOOD FRAME	100
Exterior Wall	02	HARDIE BRD	50
Exterior Wall	15	CONC BLOCK	50
Roof Structur	03	GABLE/HIP	100
Roof Cover	13	GALVALUM	100
Interior Wall	04	PLYWOOD	50
Interior Wall	05	DRYWALL	50
Interior Floo	07	VYL PLANK	50
Interior Floo	11	CLAY TILE	50
Heating Type	04	AIR DUCTED	100
Air Condition	03	CENTRAL	100
Bedrooms		4	100
Bathrooms		4	100
Story Height		0	100
Stories	2.	2.	100
Units		0	100
Quality	03	AVERAGE	
DOR CODE	0100	SINGLE FAMILY	
MAP NUM	4	MKT AREA	03
NEIGHBORHOOD/LOC	75.00	1.00/	
AREA TYPE	TOTAL GROSS AREA	PCT OF BASE	YEAR
BAS	1,280	100	1993
DCK	16	10	1993
DCK	75	10	1993
DCK	16	10	1999
FCP	200	25	2010
FOP	68	30	2010
FSP	192	55	1999
FUS	673	100	1993
FUS	960	100	1993
UOP	240	20	1993
TOTALS	4,572		

MARKET ADJUSTMENTS													
TYPE	MDL	EFF. AREA	TOT ADJ PTS	EFF. BASE RATE	REPL. COST NEW	AYB	EYB	ECON	FNCT	NORM	% COND		
0100	01	3,517	120.0000	114.00	400,938	1963	2010	0	0	0	13.00	87.00	
1 SINGLE FAM 0% - 2023 Heated Area: 2913 HX Base Yr													



** This building has 14 Sub-Areas

BLD DATE	11/20/2018	MMSS	LGL DATE	
XF DATE	11/20/2018	MMSS	LAND DATE	11/20/2018
INC DATE			AG DATE	

2509 SURF RD, PANACEA

EXTRA FEATURES																	
L N	OB/XF CODE	DESCRIPTION	BLD	CAP	L	W	UNITS	UT	Adj R	ADJ UNIT PRICE	ORIG COND	YEAR ON	YEAR ACTUAL	Q	% COND	OB/XF MKT VALUE	NOTES
1	0211	CONCRETE W	0	0	22	4	88.00	SF	6.00	6.00	100	2003	2003	3	21	111	
2	0211	CONCRETE W	0	0	24	6	144.00	SF	6.00	6.00	100	2005	2005	3	24	207	
3	0001	BLOCK UTIL	0	0	12	10	120.00	SF	16.00	16.00	100	1963	1963	3	20	384	
4	0960	SCREEN ROO	0	0	12	6	72.00	SF	21.00	21.00	100	1963	1963	3	20	302	

TOTAL OB/XF 1,004

LAND DESCRIPTION																							
L N	USE CODE	CLS	LAND USE DESCRIPTION	CAP	R D	LOC ZONE	FRONT	DEPTH	TOT LND UTS	UNIT TYPE	D T	% COND	TOT ADJ	UNIT PRICE	ADJ UNIT PRICE	LAND VALUE	OTHER ADJUSTMENTS AND NOTES	YEAR	DENSITY	DECL	FRZ	YR	CONSRV
1	000132	C	SFR RIVER	0			80.00	273.00	80.00	FF		1.00	1.00	1,650.00	1,650.00	132,000							

WAKULLA COUNTY PROPERTY			
VALUATION SUMMARY			PAGE 1 of 1
VALUATION BY		STANDARD	
Tax Group: 3		Tax Dist:	
BUILDING MARKET VALUE	348,816		
TOTAL MARKET OB/XF VALUE	1,004		
TOTAL LAND VALUE - MARKET	132,000		
TOTAL MARKET VALUE	481,820		
SOH/AGL Deduction	4,679		
ASSESSED VALUE	477,141		
TOTAL EXEMPTION VALUE	0		
BASE TAXABLE VALUE	477,141		
TOTAL JUST VALUE	481,820		
NCON VALUE	0		
INCOME VALUE	0		
PREVIOUS YEAR MKT VALUE	433,765		
CERTIFIED MAIL RTND, UNABLE TO FORWARD			
NO RESPONSE.			
SSN. LEFT SEVERAL VMails ALSO MAILD LETTER W/			
DN HX APP INCOMPLETE, DID NOT PROVIDE SPOU			
PERMIT NUM	DESCRIPTION	AMT	ISSUED
2013560	RE-ROOF	0	08/12/2013
2009682	REM NON RES STRUC	0	08/13/2009
028150	DOCK	0	08/30/2001

SALES DATA						
OFF RECORD Number	DATE	TYPE INST	Q U	V I	RSN CD	SALE PRICE
1264/0186	5/05/2022	WD Q	Q	I	01	530,000
GRANTOR: SMITH KAY WOODHAM TRU						
GRANTEE: NORTH JASON F & CAR						
1239/0401	11/18/2021	WD U	U	I	11	100
GRANTOR: SMITH KAY WOODHAM						
GRANTEE: SMITH KAY WOODHAM &						

BUILDING NOTES													

BUILDING DIMENSIONS													
USP=[YR=1993] W24 S10 E22 BAS=[YR=1993] W20 S14 W15 S20 E50													
UOP=[YR=1993] W20 S12 E20 DCK=[YR=1993] E4 N4 W4 S4\$													
FCP=[YR=2010] W20 S10 E20 UST=[YR=1993] W20 S21 PTR=E30													
UST=[YR=1993] N12 W10 S12 USP=[YR=1993] N12 W6 S12 E6\$ E10\$													
W30\$ E20 N21\$ N10\$ N12\$ N20 W15 N14\$ E2 N10\$ PTR=E35													
FSP=[YR=1999] S8 E24 FUS=[YR=1993] W24 DCK=[YR=1999] N4 W4 S4													
E4\$ S40 E24 DCK=[YR=1993] S5 E7 S3 E5 FUS=[YR=1993] W5 N3 W11													
S3 W4 S32 E20 N32\$ N8 W12\$ FOP=[YR=2010] W10 S8 E6 N3 E4 N5\$													
N40\$ N8 W24\$ W35\$.													