

TARPON SHORES SUBD UNIT 1
 LOT 8
 OR 55 P 638 & OR 61 P 532

SHIVER RENTAL PARTNERSHIP
 P O BOX 1734
 TIFTON, GA 31793

2024

02-6S-02W-033-03625-000



BUILDING CHARACTERISTICS	
ELEMENT	CD
Foundation	05 PILE CONCR 100
Frame	30 WOOD FRAME 100
Exterior Wall	02 VINYL 100
Roof Structur	03 GABLE/HIP 100
Roof Cover	12 MODULAR MT 100
Interior Wall	05 DRYWALL 100
Interior Floor	11 CLAY TILE 50
Interior Floor	12 HARDWOOD 50
Heating Type	04 AIR DUCTED 100
Air Condition	03 CENTRAL 100
Bedrooms	4 100
Bathrooms	3 100
Story Height	0 100
Stories	2. 100
Units	0 100

MARKET ADJUSTMENTS														
TYPE	MDL	EFF. AREA	TOT ADJ PTS	EFF. BASE RATE	REPL. COST NEW	AYB	EYB	ECON	FNCT	NORM	% COND			
0100	01	3,055	163.3000	155.14	473,953	2005	2005	0	0	0	18.00	82.00		
1 SINGLE FAM 0% - 0 Heated Area: 2429 HX Base Yr														

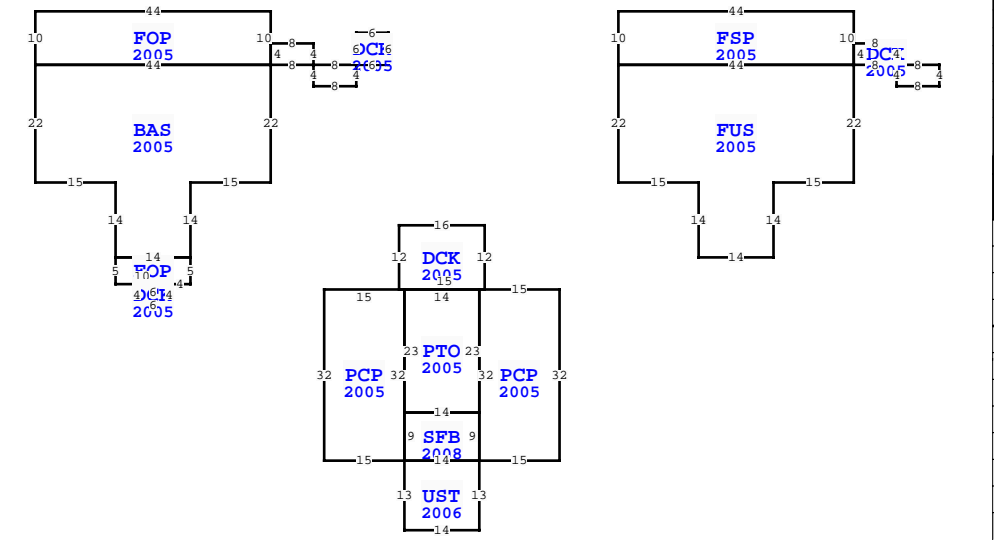

Quality	07 GOOD				
DOR CODE	0100 SINGLE FAMILY				
MAP NUM	4 MKT AREA 03				
NEIGHBORHOOD/LOC	75.00 1.00/				
AREA TYPE	TOTAL GROSS AREA	PCT OF BASE	YEAR	TOT ADJ AREA	SUBAREA MARKET VALUE
BAS	1,164	100	2005	1,164	148,078
DCK	24	10	2005	2	254
DCK	64	10	2005	6	763
DCK	100	10	2005	10	1,272
DCK	192	10	2005	19	2,417
FOP	70	30	2005	21	2,672
FOP	440	30	2005	132	16,792
FSP	440	55	2005	242	30,786
FUS	1,164	100	2005	1,164	148,078
PCP	480	10	2005	48	6,107
TOTALS	5,248			3,055	388,641

** This building has 14 Sub-Areas

BLD DATE	05/03/2019	MMJTT	LGL DATE	
XF DATE	05/03/2019	MMJTT	LAND DATE	05/03/2019 MMJTT
INC DATE			AG DATE	

WAKULLA COUNTY PROPERTY PAGE 1 of 1 3

VALUATION SUMMARY		STANDARD
VALUATION BY		
Tax Group: 3	Tax Dist:	
BUILDING MARKET VALUE		388,641
TOTAL MARKET OB/XF VALUE		38,050
TOTAL LAND VALUE - MARKET		132,000
TOTAL MARKET VALUE		558,691
SOH/AGL Deduction		42,627
ASSESSED VALUE		516,064
TOTAL EXEMPTION VALUE		0
BASE TAXABLE VALUE		516,064
TOTAL JUST VALUE		558,691
NCON VALUE		0
INCOME VALUE		
PREVIOUS YEAR MKT VALUE		510,195

5 YR PRCL CH, N/C
 5 YR PRCL CH, DEL XFOB LN 10 (NOW P/O SFB2008)
 XFOB LN 1 & 4, PU XFOB LN 6-10
 5 YR PRCL CH, PU FNDN, NEW TRAV, CHG DIMENS

PERMIT NUM	DESCRIPTION	AMT	ISSUED
2009680	DOCKS/SEAWALL	0	08/13/2009
31487	SFD	0	03/10/2004

SALES DATA

OFF RECORD Number	DATE	TYPE INST	Q U	V I	RSN CD	SALE PRICE
0699/0526	3/01/2007	WD	U	I		1,150,000
GRANTOR: BRANNON ROSS F & SHIV						
GRANTEE: SHIVER RENTAL PARTN						
0632/0135	12/16/2005	QC	Q	I		809,800
GRANTOR: MOSSY OAK REAL ESTATE						
GRANTEE: BRANNON/SHIVER						

BUILDING NOTES

BUILDING DIMENSIONS

FOP=[YR=2005] W44 S10 E44 DCK=[YR=2005] E8 S4 E8 N4 E6 N6 W6 S6 W8 N4 W8 S4\$ BAS=[YR=2005] W44 S22 E15 S14 E14
 FOP=[YR=2005] W14 S5 E10 DCK=[YR=2005] W6 S4 E6 N4\$ E4 N5\$ N14 E15 PTR=E10 S20 PCP=[YR=2005] S32 E15 UST=[YR=2006] S13 E14 N13 W14\$ SFB=[YR=2008] E14 N9 W14 S9\$ N32 PTO=[YR=2005] S23 E14 N23 PCP=[YR=2005] S32 E15 N32 W15\$ W14\$ DCK=[YR=2005] E15 N12 W16 S12 E1\$ W15\$ N20 W10\$ PTR=E65 FUS=[YR=2005] E15 S14 E14 N14 E15 N22 DCK=[YR=2005] E8 S4 E8 N4 W8 N4 W8 S4\$ FSP=[YR=2005] N10 W44 S10 E44\$ W44 S22\$ W65\$ N22\$ N10\$.

EXTRA FEATURES																	
L N	OB/XF CODE	DESCRIPTION	BLD	CAP	L	W	UNITS	UT	Adj R	ADJ UNIT PRICE	ORIG COND	YEAR ON	YEAR ACTUAL	Q	% COND	OB/XF MKT VALUE	NOTES
1	0210	CONCRETE D	0	0	33	15	495.00	SF	6.00	6.00	100	2005	2005	3	24	713	
2	0005	ELEVATOR	0	0	0	0	1.00	UT	29,000.00	29,000.00	100	2005	2005	3	64	18,560	
3	0210	CONCRETE D	0	0	33	15	495.00	SF	6.00	6.00	100	2005	2005	3	24	713	
4	0125	MTL/VYL AC	0	0	0	0	588.00	LF	19.00	19.00	100	2008	2008	3	34	3,798	
5	0375	WOOD WALK	0	0	87	4	348.00	SF	15.00	15.00	100	2009	2009	3	39	2,036	
6	0007	ELECTRIC L	0	0	0	0	2.00	UT	7,500.00	7,500.00	100	2009	2009	3	39	5,850	
7	0350	BOATDOCK A	0	0	18	17	306.00	SF	26.40	26.40	100	2009	2009	GD	39	3,151	
8	0330	BOAT SHED	0	0	30	12	360.00	SF	15.00	15.00	100	2009	2009	3	39	2,106	
9	0330	BOAT SHED	0	0	16	12	192.00	SF	15.00	15.00	100	2009	2009	3	39	1,123	

TOTAL OB/XF 38,050

LAND DESCRIPTION														TOTAL OB/XF										
L N	USE CODE	CLS	LAND USE DESCRIPTION	CAP	R D	LOC ZONE	FRONT	DEPTH	TOT LND UTS	UNIT TYPE	D T	DPHT FACT	% COND	TOT ADJ	UNIT PRICE	ADJ UNIT PRICE	LAND VALUE	OTHER ADJUSTMENTS AND NOTES	YEAR	DENSITY	DECL	FRZ	YR	CONSRV
1	000130	C	SFR WATER	0			80.00	256.00	80.00	FF		1.00	1.00	1.00	1,650.00	1,650.00	132,000							