

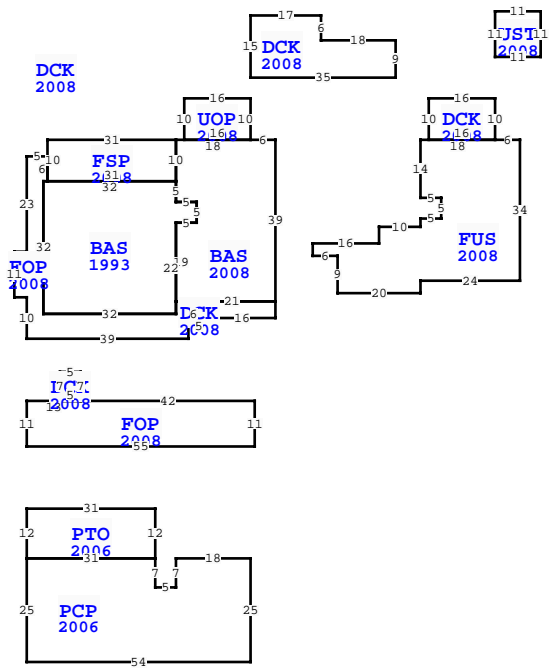

BUILDING CHARACTERISTICS		
ELEMENT	CD	CONSTRUCTION
Foundation	05	PILE CONCR 100
Frame	02	WOOD FRAME 100
Exterior Wall	30	VINYL 100
Roof Structur	03	GABLE/HIP 100
Roof Cover	03	COMP SHNGL 100
Interior Wall	05	DRYWALL 50
Interior Wall	06	CUST PANEL 50
Interior Floor	12	HARDWOOD 100
Heating Type	04	AIR DUCTED 100
Air Condition	03	CENTRAL 100
Bedrooms		4 100
Bathrooms		2 100
Story Height		0 100
Stories	1.5	1.5 100
Units		0 100
Quality	03	AVERAGE
DOR CODE	0100	SINGLE FAMILY
MAR NUM	4	MKT AREA
NEIGHBORHOOD/LOC	75.00	1.00/
AREA TYPE	TOTAL GROSS AREA	PCT OF BASE
BAS	1,049	100
BAS	911	100
DCK	16	10
DCK	35	10
DCK	94	10
DCK	160	10
DCK	417	10
FOP	434	30
FOP	605	30
FSP	310	55
TOTALS	7,088	

MARKET ADJUSTMENTS											
TYPE	MDL	EFF. AREA	TOT ADJ PTS	EFF. BASE RATE	REPL. COST NEW	AYB	EYB	ECON	FNCT	NORM	% COND
1	SINGLE FAM	100%	- 2002		487,116	2006	2010	0	0	13.00	87.00
Heated Area: 3049 HX Base Yr 2002											



** This building has 15 Sub-Areas

BLD DATE	08/09/2018	MMSS	LGL DATE	
XF DATE	08/09/2018	MMSS	LAND DATE	08/09/2018
INC DATE			AG DATE	

WAKULLA COUNTY PROPERTY			
VALUATION SUMMARY		PAGE 1 of 2	
VALUATION BY	Tax Group: 3	Tax Dist:	STANDARD
BUILDING MARKET VALUE			423,791
TOTAL MARKET OB/XF VALUE			45,959
TOTAL LAND VALUE - MARKET			132,000
TOTAL MARKET VALUE			601,750
SOH/AGL Deduction			406,128
ASSESSED VALUE			195,622
TOTAL EXEMPTION VALUE	HX HB		50,000
BASE TAXABLE VALUE			145,622
TOTAL JUST VALUE			601,750
NCON VALUE			245
INCOME VALUE			
PREVIOUS YEAR MKT VALUE			547,006
MM 5YR CK CORR DIMENS XFOB, CHG XFOB CODE, PU XFOB			
ADDED SPOUSE INFO			
0451 SURF RD.			
CORRECT ADDRESS ON PRCL SCREEN WAS LISTED AS			
PERMIT NUM	DESCRIPTION	AMT	ISSUED
OB22-000114	RE-ROOF-CC	0	02/24/2022
16000810	RE-ROOF	0	08/19/2016
20061449	COVERED WLKWAY-CO	0	09/05/2006
2006464	ADDITION-CO	0	03/13/2006
2006396	PILINGS FOR ADDIT	0	03/03/2006
20051476	MOVE SFD	0	09/02/2005
SALES DATA			
OFF RECORD Number	DATE	TYPE INST	Q / V / I / RSN CD
0395/0230	12/01/2000	WD Q	I
GRANTOR: WEIMER LESTER C & PAT			
GRANTEE: REVELL E GUY JR			
0354/0483	5/28/1999	WD U	I
GRANTOR: WEIMER LESTER C & PAT			
GRANTEE:			
BUILDING NOTES			
BUILDING DIMENSIONS			
BAS=[YR=2008] W6 PTR= N15 DCK=[YR=2008] N15 E17 S6 E18 S9 W35\$ S15\$ UOP=[YR=2008] N10 W16 S10 E16\$ W18 FSP=[YR=2008] W31 PTR= N15 DCK=[YR=2008] N4 E4 S4 W4\$ S15\$ S10 E31 N10\$ S10 BAS=[YR=1993] W32 FOP=[YR=2008] E1 N6 W5 S23 W3 S11 E3 S10 PTR= S15 FOP=[YR=2008] S11 PTR=S15 PTO=[YR=2006] S12 E31 PCP=[YR=2006] W31 S25 E54 N25 W18 S7 W5 N7\$ N12 W31\$ N15\$ E55 N11 W42 DCK=[YR=2008] N7 W5 S7 E5\$ W13\$ N15\$ E39 N9 W3 S3 W32 N32\$ S32 E32 N22 E5 N5 W5 N5\$ S5 E5 S5 W5 S19 E3 DCK=[YR=2008] S6 E5 N2 E16 N4 W21\$ E21 N39\$ PTR= E35 FUS=[YR=2008] S14 E5 S5 W5 S2 W10 S4 W16 S3 E6 S9 E20 N3 E24 N34W6 DCK=[YR=2008] N10 PTR= N10 UST=[YR=2008] E11 N11 W11 S11\$ S10\$W16 S10 E16\$ W18\$ W35\$.			

EXTRA FEATURES																
L N	OB/XF CODE	DESCRIPTION	BLD CAP	L	W	UNITS	UT	Adj R	ADJ UNIT PRICE	ORIG COND	YEAR ON	YEAR ACTUAL	Q	% COND	OB/XF MKT VALUE	NOTES
1	0220	POOL VINYL	0 100	16	32	512.00	SF	60.00	60.00	100	1992	1992	3	40	12,288	
2	0870	SEAWALL AL	0 100	111	0	111.00	LF	51.00	51.00	100	2001	2001	3	20	1,132	
3	0350	BOATDOCK A	0 100	16	12	192.00	SF	24.00	24.00	100	1993	1993	3	20	922	
4	0375	WOOD WALK	0 100	130	4	520.00	SF	15.00	15.00	100	1993	1993	3	20	1,560	
5	0007	ELECTRIC L	0 100	0	0	2.00	UT	7,500.00	7,500.00	100	2001	2001	3	20	3,000	
6	0330	BOAT SHED	0 100	38	14	532.00	SF	15.00	15.00	100	2002	2002	3	20	1,596	
7	0840	SEAWALL RI	0 100	0	0	80.00	LF	38.00	38.00	100	2008	2008	3	34	1,034	
8	0005	ELEVATOR	0 100	0	0	1.00	UT	29,000.00	29,000.00	100	2008	2008	3	70	20,300	
9	0140	FIRE PLACE	0 100	0	0	1.00	UT	1,900.00	1,900.00	100	2008	2008	3	70	1,330	
10	0140	FIRE PLACE	0 100	0	0	1.00	UT	1,900.00	1,900.00	100	2008	2008	3	70	1,330	
TOTALS															44,492	

LAND DESCRIPTION															TOTAL OB/XF									
L N	USE CODE	CLS	LAND USE DESCRIPTION	CAP	R D	LOC ZONE	FRONT	DEPTH	TOT LND UTS	UNIT TYPE	D T	DPTH FACT	% COND	TOT ADJ	UNIT PRICE	ADJ UNIT PRICE	LAND VALUE	OTHER ADJUSTMENTS AND NOTES	YEAR	DENSITY	DECL	FRZ	YR	CONSRV
1	000132	C	SFR RIVER	100			80.00	245.00	80.00	FF		1.00	1.00	1.00	1,650.00	1,650.00	132,000							

