

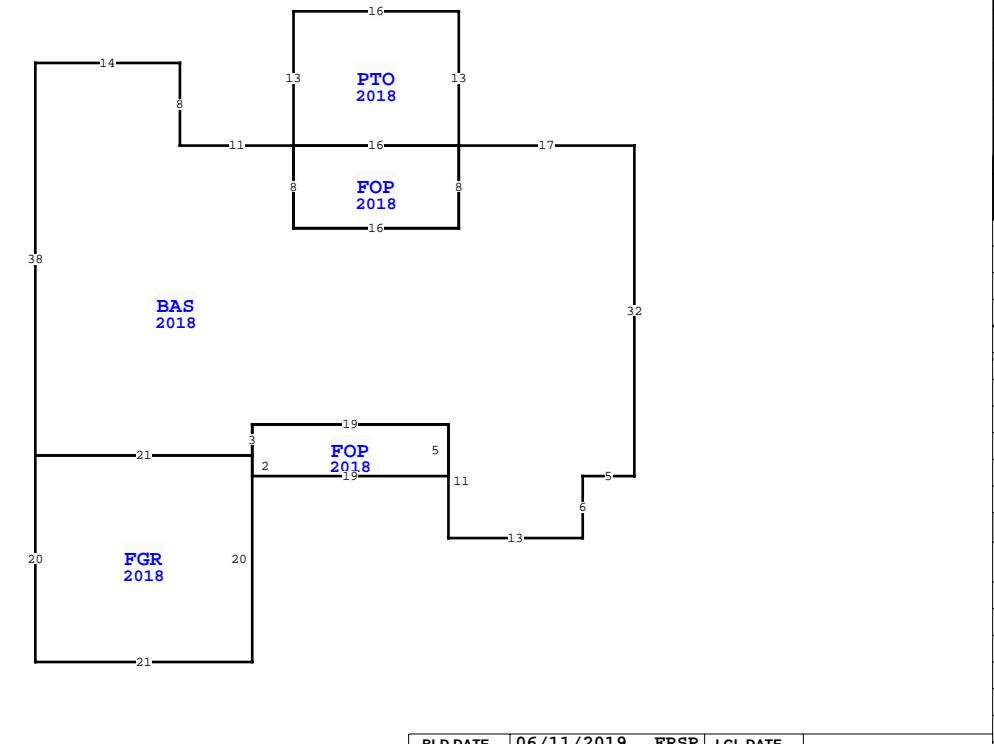

BUILDING CHARACTERISTICS		
ELEMENT	CD	CONSTRUCTION
Foundation	02	CONCR SLAB 100
Frame	02	WOOD FRAME 100
Exterior Wall	05	HARDIE BRD 100
Roof Structur	03	GABLE/HIP 100
Roof Cover	03	COMP SHNGL 100
Interior Wall	05	DRYWALL 100
Interior Floor	07	VYL PLANK 50
Interior Floor	14	CARPET 50
Heating Type	04	AIR DUCTED 100
Air Condition	03	CENTRAL 100
Bedrooms		4 100
Bathrooms		3 100
Story Height		0 100
Stories	1.	1. 100
Units		0 100

MARKET ADJUSTMENTS												
TYPE	MDL	EFF. AREA	TOT ADJ PTS	EFF. BASE RATE	REPL. COST NEW	AYB	EYB	ECON	FNCT	NORM	% COND	
0100	01	2,067	116.5000	110.68	228,776	2018	2018	0	0	0	5.00	95.00



Quality	03	AVERAGE			
DOR CODE	0100	SINGLE FAMILY			
MAP NUM	2	MKT AREA 10			
NEIGHBORHOOD/LOC	000	1.00/			
AREA TYPE	TOTAL GROSS AREA	PCT OF BASE	YEAR	TOT ADJ AREA	SUBAREA MARKET VALUE
BAS	1,781	100	2018	1,781	187,265
FGR	420	50	2018	210	22,081
FOP	95	30	2018	28	2,944
FOP	128	30	2018	38	3,996
PTO	208	5	2018	10	1,052
TOTALS	2,632			2,067	217,337

WAKULLA COUNTY PROPERTY			
VALUATION SUMMARY			PAGE 1 of 1
VALUATION BY			STANDARD
Tax Group: 3	Tax Dist:		
BUILDING MARKET VALUE			217,337
TOTAL MARKET OB/XF VALUE			7,580
TOTAL LAND VALUE - MARKET			28,425
TOTAL MARKET VALUE			253,342
SOH/AGL Deduction			35,398
ASSESSED VALUE			217,944
TOTAL EXEMPTION VALUE	HX HB		50,000
BASE TAXABLE VALUE			167,944
TOTAL JUST VALUE			253,342
NCON VALUE			0
INCOME VALUE			
PREVIOUS YEAR MKT VALUE			256,156
5 YR PRCL CH, PU NEW SFD & XFOB LN 1-5			
ADD HX FOR 2019- BURCH			
N IN ARNWL FIELD			
S/O LOT 24 (1.61 AC) TO NEW PRCL 04289-024			
PERMIT NUM	DESCRIPTION	AMT	ISSUED
17001089	SFD-CO	0	08/30/2017
22971	N/A	0	11/25/1997

SALES DATA						
OFF RECORD Number	DATE	TYPE INST	Q / U	V / I	RSN CD	SALE PRICE
1087/0539	9/25/2018	WD Q	Q	V	01	291,900
GRANTOR: SOUTHERN CONSTRUCTION						
GRANTEE: BURCH JUSTIN D & KO						
1038/0001	6/16/2017	WD Q	Q	V	01	103,800
GRANTOR: BRITTLE PHYLLIS W						
GRANTEE: SOUTHERN CONSTRUCTI						

EXTRA FEATURES																	
L N	OB/XF CODE	DESCRIPTION	BLD	CAP	L	W	UNITS	UT	Adj R	ADJ UNIT PRICE	ORIG COND	YEAR ON	YEAR ACTUAL	Q	% COND	OB/XF MKT VALUE	NOTES
1	0210	CONCRETE D	0	100	0	0	901.00	SF	6.00	6.00	100	2018	2018	3	80	4,325	
2	0211	CONCRETE W	0	100	62	4	248.00	SF	6.00	6.00	100	2018	2018	3	80	1,190	
3	0060	DECK WOOD	0	100	11	16	176.00	SF	5.00	5.00	100	2018	2018	3	95	836	
4	0940	OPEN SHED	0	100	9	16	144.00	SF	4.00	4.00	100	2018	2018	3	80	461	
5	0625	PORT WD UT	0	100	10	16	160.00	SF	6.00	6.00	100	2018	2018	3	80	768	

BUILDING NOTES			

BUILDING DIMENSIONS			
BAS=[YR=2018] W17 PTO=[YR=2018] N13 W16 S13 E16\$			
FOP=[YR=2018] W16 S8 E16 N8 \$ S8 W16 N8 W11 N8 W14 S38			
FGR=[YR=2018] S20 E21 N20 W21\$ E21 FOP=[YR=2018] S2 E19 N5			
W19 S3\$ N3 E19 S11 E13 N6 E5 N32\$.			

LAND DESCRIPTION																								
L N	USE CODE	CLS	LAND USE DESCRIPTION	CAP	R D	LOC ZONE	FRONT	DEPTH	TOT LND UTS	UNIT TYPE	D T	DPH FACT	% COND	TOT ADJ	UNIT PRICE	ADJ UNIT PRICE	LAND VALUE	OTHER ADJUSTMENTS AND NOTES	YEAR	DENSITY	DECL	FRZ	YR	CONSRV
1	000100	C	SFR	100			0.00	0.00	3.79	AC		1.00	1.00	1.00	7,500.00	7,500.00	28,425							