

| BUILDING CHARACTERISTICS | | |
|--------------------------|----|----------------|
| ELEMENT | CD | CONSTRUCTION |
| Foundation | 05 | PILE CONCR 100 |
| Frame | 02 | WOOD FRAME 100 |
| Exterior Wall | 05 | HARDIE BRD 50 |
| Exterior Wall | 08 | WD ON PLY 50 |
| Roof Structur | 03 | GABLE/HIP 100 |
| Roof Cover | 12 | MODULAR MT 100 |
| Interior Wall | 05 | DRYWALL 100 |
| Interior Floo | 12 | HARDWOOD 100 |
| Heating Type | 04 | AIR DUCTED 100 |
| Air Condition | 03 | CENTRAL 100 |
| Bedrooms | | 3 100 |
| Bathrooms | | 2 100 |
| Story Height | | 0 100 |
| Stories | 1. | 1. 100 |
| Units | | 0 100 |

| MARKET ADJUSTMENTS | | | | | | | | | | | | |
|--|-----|-----------|-------------|----------------|----------------|------|------|------|------|------|--------|-------|
| TYPE | MDL | EFF. AREA | TOT ADJ PTS | EFF. BASE RATE | REPL. COST NEW | AYB | EYB | ECON | FNCT | NORM | % COND | |
| 0100 | 01 | 3,106 | 137.0000 | 130.15 | 404,246 | 1982 | 1990 | 0 | 0 | 0 | 33.00 | 67.00 |
| 1 SINGLE FAM 0% - 0 Heated Area: 1936 HX Base Yr | | | | | | | | | | | | |

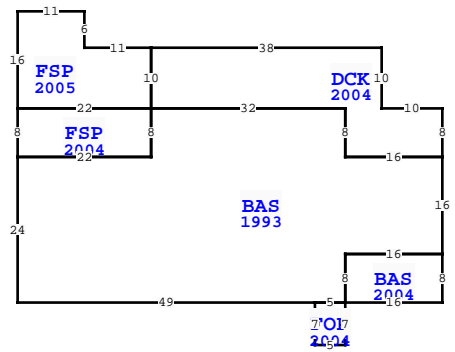
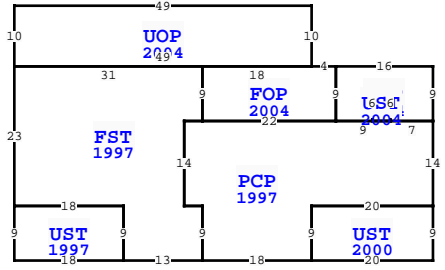

| WAKULLA COUNTY PROPERTY | | | |
|-------------------------------------|-------------|-----------|-------------|
| VALUATION SUMMARY | | | PAGE 1 of 2 |
| VALUATION BY | | STANDARD | |
| Tax Group: 2 | | Tax Dist: | |
| BUILDING MARKET VALUE | | 270,845 | |
| TOTAL MARKET OB/XF VALUE | | 19,676 | |
| TOTAL LAND VALUE - MARKET | | 45,000 | |
| TOTAL MARKET VALUE | | 335,521 | |
| SOH/AGL Deduction | | 0 | |
| ASSESSED VALUE | | 335,521 | |
| TOTAL EXEMPTION VALUE | | 0 | |
| BASE TAXABLE VALUE | | 335,521 | |
| TOTAL JUST VALUE | | 335,521 | |
| NCON VALUE | | 0 | |
| INCOME VALUE | | 0 | |
| PREVIOUS YEAR MKT VALUE | | 339,192 | |
| 5YR PRCL CK NC JS | | | |
| EMLD DR501R TO ESCAMBIA FOR CANTNER | | | |
| REMOVE H1 | | | |
| COA PER NCOA REPORT | | | |
| PERMIT NUM | DESCRIPTION | AMT | ISSUED |
| 15000668 | MECH | 0 | 07/21/2015 |
| 20071211 | SIDING | 0 | 09/06/2007 |
| 2007979 | REROOF | 0 | 07/09/2007 |
| 32268 | UP ELEC | 0 | 08/18/2004 |
| 31691 | ADDITION | 0 | 04/20/2004 |
| 18630 | N/A | 0 | 06/11/1994 |

| QUALITY | CD | CONSTRUCTION | | | |
|------------------|------------------|---------------|------|--------------|----------------------|
| 03 | | AVERAGE | | | |
| DOR CODE | 0100 | SINGLE FAMILY | | | |
| MAP NUM | 1 | MKT AREA 07 | | | |
| NEIGHBORHOOD/LOC | 000 | 1.00/ | | | |
| AREA TYPE | TOTAL GROSS AREA | PCT OF BASE | YEAR | TOT ADJ AREA | SUBAREA MARKET VALUE |
| BAS | 1,808 | 100 | 1993 | 1,808 | 157,658 |
| BAS | 128 | 100 | 2004 | 128 | 11,162 |
| DCK | 508 | 10 | 2004 | 51 | 4,447 |
| FOP | 35 | 30 | 2004 | 10 | 872 |
| FOP | 198 | 30 | 2004 | 59 | 5,145 |
| FSP | 176 | 55 | 2004 | 97 | 8,459 |
| FSP | 286 | 55 | 2005 | 157 | 13,691 |
| FST | 788 | 55 | 1997 | 433 | 37,758 |
| PCP | 736 | 10 | 1997 | 74 | 6,453 |
| UOP | 144 | 20 | 2004 | 29 | 2,529 |
| TOTALS | 5,657 | | | 3,106 | 270,845 |

** This building has 14 Sub-Areas

| | | | | |
|----------|------------|-------|-----------|------------|
| BLD DATE | 06/15/2018 | RTJ/T | LGL DATE | |
| XF DATE | 06/15/2018 | RTJ/T | LAND DATE | 06/15/2018 |
| INC DATE | | | AG DATE | |

| EXTRA FEATURES | | | | | | | | | | | | | | | | | |
|----------------|------------|-------------|-----|-----|----|-----|--------|----|-------|----------------|-----------|---------|-------------|---|--------|-----------------|-------|
| L N | OB/XF CODE | DESCRIPTION | BLD | CAP | L | W | UNITS | UT | Adj R | ADJ UNIT PRICE | ORIG COND | YEAR ON | YEAR ACTUAL | Q | % COND | OB/XF MKT VALUE | NOTES |
| 1 | 0360 | BOATDOCK F | 0 | 0 | 24 | 13 | 312.00 | SF | 15.00 | 15.00 | 100 | 1987 | 1987 | 3 | 20 | 936 | |
| 2 | 0210 | CONCRETE D | 0 | 0 | 42 | 14 | 588.00 | SF | 6.00 | 6.00 | 100 | 1988 | 1988 | 3 | 20 | 706 | |
| 3 | 0375 | WOOD WALK | 0 | 0 | 4 | 184 | 736.00 | SF | 15.00 | 15.00 | 100 | 1997 | 1997 | 3 | 20 | 2,208 | |
| 4 | 0060 | DECK WOOD | 0 | 0 | 10 | 12 | 120.00 | SF | 5.00 | 5.00 | 100 | 1997 | 1997 | 3 | 20 | 120 | |
| 5 | 0375 | WOOD WALK | 0 | 0 | 5 | 40 | 200.00 | SF | 15.00 | 15.00 | 100 | 1997 | 1997 | 3 | 20 | 600 | |
| 6 | 0213 | CONCRETE P | 0 | 0 | 8 | 5 | 40.00 | SF | 6.00 | 6.00 | 100 | 2000 | 2000 | 3 | 100 | 240 | |
| 7 | 0211 | CONCRETE W | 0 | 0 | 37 | 4 | 148.00 | SF | 6.00 | 6.00 | 100 | 1988 | 1988 | 3 | 20 | 178 | |
| 8 | 0211 | CONCRETE W | 0 | 0 | 12 | 4 | 48.00 | SF | 6.00 | 6.00 | 100 | 1988 | 1988 | 3 | 20 | 58 | |
| 9 | 0211 | CONCRETE W | 0 | 0 | 5 | 5 | 25.00 | SF | 6.00 | 6.00 | 100 | 1988 | 1988 | 3 | 20 | 30 | |
| 10 | 0211 | CONCRETE W | 0 | 0 | 6 | 7 | 42.00 | SF | 6.00 | 6.00 | 100 | 1988 | 1988 | 3 | 20 | 50 | |

133 FORBES ST, ST MARKS

| SALES DATA | | | | | | |
|--------------------------------|------------|-----------|-------|-------|--------|------------|
| OFF RECORD Number | DATE | TYPE INST | Q / U | V / I | RSN CD | SALE PRICE |
| 1363/0253 | 6/24/2024 | WD | Q | I | 01 | 370,000 |
| GRANTOR: THOMPSON MICHAEL J SR | | | | | | |
| GRANTEE: 133 FORBES LLC | | | | | | |
| 1182/0448 | 12/02/2020 | WD | Q | I | 05 | 369,000 |
| GRANTOR: CANTNER MICKEY F & CA | | | | | | |
| GRANTEE: THOMPSON MICHAEL J | | | | | | |

| BUILDING NOTES | | | | | | | | | | | | |
|----------------|--|--|--|--|--|--|--|--|--|--|--|--|
|----------------|--|--|--|--|--|--|--|--|--|--|--|--|

| BUILDING DIMENSIONS | | | | | | | | | | | | |
|--|--|--|--|--|--|--|--|--|--|--|--|--|
| UOP=[YR=2004] W16 S9 E16 PCP=[YR=1997] W7 UST=[YR=2004] N6 W3 S6 E3\$ W9 FOP=[YR=2004] N9 W4 UOP=[YR=2004] N10 W49 S10 E49\$ W18 S9 E22\$ W22 FST=[YR=1997] N9 W31 S23 UST=[YR=1997] S9 E18 N9 W18\$ E18 S9 E13 N9 W3 N14 E3\$ W3 S14 E3 S9 E18 UST=[YR=2000] E20 PTR=E10 BAS=[YR=1993] E49 FOP=[YR=2004] S7 E5 N7 W5\$ E5 BAS=[YR=2004] E16 N8 W16 S8\$ N8 E16 N16 DCK=[YR=2004] N8 W10 N10 W38 S10 E32 S8 E16\$ W16 N8 W32 FSP=[YR=2005] N10 W11 N6 W11 S16 E22 \$ FSP=[YR=2004] W22 S8 E22 N8\$ S8 W22 S24\$ W10\$ N9 W20 S9\$ N9 E20 N14\$ N9\$. | | | | | | | | | | | | |

| LAND DESCRIPTION | | | | | | | | | | | | | TOTAL OB/XF | | | | | | | | | | | | |
|------------------|----------|-----|----------------------|-----|-----|----------|--------|--------|-------------|-----------|-----|-----------|-------------|---------|------------|----------------|------------|-----------------------------|------|---------|------|-----|----|--------|--|
| L N | USE CODE | CLS | LAND USE DESCRIPTION | CAP | R D | LOC ZONE | FRONT | DEPTH | TOT LND UTS | UNIT TYPE | D T | DPTH FACT | % COND | TOT ADJ | UNIT PRICE | ADJ UNIT PRICE | LAND VALUE | OTHER ADJUSTMENTS AND NOTES | YEAR | DENSITY | DECL | FRZ | YR | CONSRV | |
| 1 | 000130 | C | SFR WATER | 0 | | | 103.00 | 125.00 | 3.00 | LT | | 1.00 | 1.00 | 1.00 | 15,000.00 | 15,000.00 | 45,000 | | | | | | | | |

