

INDIAN SUMMER
A PORTION OF LOTS 12,13 & 14
OR 47 P 435 OR 48 P 113-114

PHILLIPS WILLIAM SHANNON
P O BOX 373
SOPCHOPPY, FL 32358

2024

12-5S-03W-063-00745-000



ELEMENT		CD		CONSTRUCTION	
Foundation	01	WOOD	FRAME	100	
Frame	02	WOOD	FRAME	100	
Exterior Wall	04	SINGLE	SID	100	
Roof Structur	03	GABLE/HIP		100	
Roof Cover	03	COMP	SHNGL	100	
Interior Wall	05	DRYWALL		50	
Interior Wall	06	CUST	PANEL	50	
Interior Floo	09	PINE	WOOD	70	
Interior Floo	11	CLAY	TILE	30	
Heating Type	04	AIR	DUCTED	100	
Air Condition	03	CENTRAL		100	
Bedrooms		3		100	
Bathrooms		2		100	
Story Height		0		100	
Stories	1.5	1.5		100	
Units		0		100	
Quality	03	AVERAGE			
DOR CODE	0100	SINGLE FAMILY			
MAP NUM	5	MKT AREA	02		
NEIGHBORHOOD/LOC	63.00	1.00/			
AREA TYPE	TOTAL GROSS AREA	PCT OF BASE	YEAR	TOT ADJ AREA	SUBAREA MARKET VALUE
BAS	302	100	1976	302	16,026
BAS	765	100	1996	765	40,596
DCK	16	10	1996	2	106
DCK	40	10	1996	4	212
DCK	48	10	1996	5	265
DCK	96	10	1996	10	531
DCK	440	10	1996	44	2,335
FOP	87	30	1996	26	1,380
FSP	288	55	1996	158	8,385
FUS	140	100	1976	140	7,429
TOTALS	3,104			2,281	121,046

MARKET ADJUSTMENTS											
TYPE	MDL	EFF. AREA	TOT ADJ PTS	EFF. BASE RATE	REPL. COST NEW	AYB	EYB	ECON	FNCT	NORM	% COND
0100	01	2,281	106.4000	101.08	230,563	1976	1985	0	0	47.50	52.50
1 SINGLE FAM 100% - 0 Heated Area: 2025 HX Base Yr											

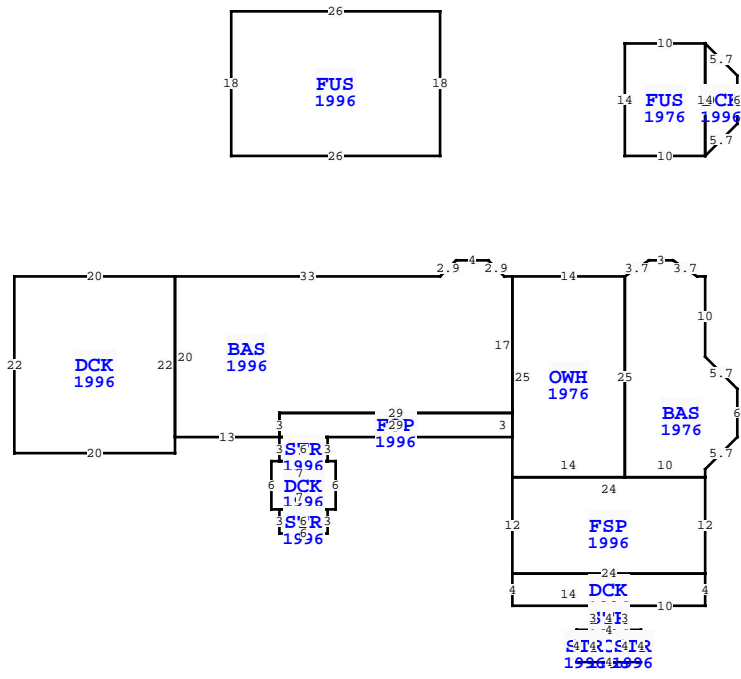

** This building has 17 Sub-Areas

BLD DATE	03/26/2018	MMJTT	LGL DATE	
XF DATE	03/26/2018	MMJTT	LAND DATE	03/26/2018
INC DATE			AG DATE	

WAKULLA COUNTY PROPERTY				PAGE 1 of 1	3
VALUATION SUMMARY				STANDARD	
VALUATION BY		Tax Group: 3		Tax Dist:	
BUILDING MARKET VALUE				121,046	
TOTAL MARKET OB/XF VALUE				5,612	
TOTAL LAND VALUE - MARKET				23,000	
TOTAL MARKET VALUE				149,658	
SOH/AGL Deduction				38,528	
ASSESSED VALUE				111,130	
TOTAL EXEMPTION VALUE		HX HB		50,000	
BASE TAXABLE VALUE				61,130	
TOTAL JUST VALUE				149,658	
NCON VALUE				0	
INCOME VALUE					
PREVIOUS YEAR MKT VALUE				148,781	
HX OK FOR 2024 ADD TO RECK LIST FOR 2025- MOTHER I					
MM 5 YR CK, CH RCVR					
5 YR PRCL CK, PU XFOB LN 9, DEL XFOB LN 13					
5 YR PRCL CH, PU XFOB LN 9, CHG LAND CODE					
PERMIT NUM	DESCRIPTION	AMT	ISSUED		
201385	RE-ROOF	0	02/12/2013		
2012525	ALTERATION-CO	0	08/08/2012		
022962	N/A	0	11/24/1997		
020395	N/A	0	12/04/1995		

SALES DATA						
OFF RECORD Number	DATE	TYPE INST	Q U	V I	RSN CD	SALE PRICE
0792/0590	5/01/2009	WD	U	I	11	100
GRANTOR: PHILLIPS WILLIAM SHAN						
GRANTEE: PHILLIPS WILLIAM SH						
0792/0589	5/01/2009	WD	U	I	11	100
GRANTOR: PHILLIPS WILLIAM SHAN						
GRANTEE: PHILLIPS WILLIAM SH						

BLDING NOTES	

BLDING DIMENSIONS	
BAS=[YR=1976] W1 U2 L3 W3 L3 D2 S25 E10 FSP=[YR=1996] W24	
OWH=[YR=1976] E14 N25 W14 PTR=N15 E14 FUS=[YR=1976] E10 N14	
DCK=[YR=1996] S14 R4 U4 N6 U4 L4 S W10 S14\$ W14 S15\$	
BAS=[YR=1996] W1 U2 L2 W4 L2 D2 W33 PTR=N15 E7	
FUS=[YR=1996] E26 N18 W26 S18\$ W7 S15\$ DCK=[YR=1996] W20 S22	
E20 N22\$ S20 E13 N3 E29 FOP=[YR=1996] W29 S3 STR=[YR=1996] S3	
E6 DCK=[YR=1996] W7 S6 E7 STR=[YR=1996] W6 S3 E6 N3\$ E1 N6	
W1\$ N3 W6\$ E29 N3\$ N17\$ S25\$ S12 E24 DCK=[YR=1996] W24 S4 E14	
STR=[YR=1996] W4 S3 E4 DCK=[YR=1996] W4 S4 STR=[YR=1996] N4	
W2 S4 E2\$ E4 N4\$ STR=[YR=1996] S4 E2 N4 W2\$ N3\$ E10 N4\$ N12\$	
N1 R4 U4 N6 U4 L4 N10\$.	

EXTRA FEATURES																
L N	OB/XF CODE	DESCRIPTION	BLD CAP	L	W	UNITS	UT	Adj R	ADJ UNIT PRICE	ORIG COND	YEAR ON	YEAR ACTUAL	Q	% COND	OB/XF MKT VALUE	NOTES
1	0935	OPEN SHED	0	100	35	20			700.00	SF	6.00	1991	1991	3	20	840
2	0060	DECK WOOD	0	100	16	20			320.00	SF	5.00	1991	1991	3	20	320
3	0375	WOOD WALK	0	100	3	73			219.00	SF	15.00	1991	1991	3	20	657
4	0620	WOOD UTL B	0	100	12	8			96.00	SF	6.00	1976	1976	3	20	115
5	0060	DECK WOOD	0	100	24	7			168.00	SF	5.00	1996	1996	3	20	168
6	0700	PORT BLDG	0	100	24	12			288.00	SF	8.00	1988	1988	3	45	1,037
7	0360	BOATDOCK F	0	100	15	6			90.00	SF	15.00	1991	1991	3	20	270
8	0130	FIRE PLACE	0	100	0	0			1.00	UT	1,300.00	1996	1996	3	53	689
9	0060	DECK WOOD	0	100	10	8			80.00	SF	5.00	2017	2017	3	91	364
10	0360	BOATDOCK F	0	100	0	0			96.00	SF	15.00	2018	2018	3	80	1,152
TOTAL OB/XF															5,612	

LAND DESCRIPTION		TOTAL OB/XF																						
L N	USE CODE	CLS	LAND USE DESCRIPTION	CAP	R D	LOC ZONE	FRONT	DEPTH	TOT LND UTS	UNIT TYPE	D T	DPTH FACT	% COND	TOT ADJ	UNIT PRICE	ADJ UNIT PRICE	LAND VALUE	OTHER ADJUSTMENTS AND NOTES	YEAR	DENSITY	DECL	FRZ	YR	CONSRV
1	000132	C	SFR RIVER	100			0.00	0.00	1.00	LT		1.00	1.00	1.00	23,000.00	23,000.00	23,000							