

ELEMENT		CD	CONSTRUCTION		
Foundation	02	CONCR	SLAB 100		
Frame	03	MASONRY	100		
Exterior Wall	06	BD/BATTEN	50		
Exterior Wall	12	CEDAR/CYPR	50		
Roof Structure	03	GABLE/HIP	100		
Roof Cover	03	COMP SHNGL	80		
Roof Cover	13	GALVALUM	20		
Interior Wall	05	DRYWALL	100		
Interior Floor	11	CLAY TILE	70		
Interior Floor	14	CARPET	30		
Heating Type	04	AIR DUCTED	100		
Air Condition	03	CENTRAL	100		
Bedrooms			3 100		
Bathrooms			2 100		
Story Height			0 100		
Stories	1.		1. 100		
Units			0 100		
Quality	03	AVERAGE			
DOR CODE	0100	SINGLE FAMILY			
MAP NUM	5	MKT AREA	13		
NEIGHBORHOOD/LOC	000		1.00/		
AREA TYPE	TOTAL GROSS AREA	PCT OF BASE	YEAR	TOT ADJ AREA	SUBAREA MARKET VALUE
BAS	2,141	100	1984	2,141	153,834
FGR	420	50	2006	210	15,089
FOP	70	30	1993	21	1,509
FOP	112	30	1993	34	2,443
FOP	24	30	2006	7	503
FSP	462	55	2003	254	18,250
FST	216	55	2006	119	8,550
PTO	60	5	1993	3	215
TOTALS	3,505			2,789	200,394

MARKET ADJUSTMENTS												
TYPE	MDL	EFF. AREA	TOT ADJ PTS	EFF. BASE RATE	REPL. COST NEW	AYB	EYB	ECON	FNCT	NORM	% COND	
1	SINGLE FAM	0%	- 0		318,085	1964	1986	0	0	37.00	63.00	
				Heated Area:	2141			HX Base Yr				

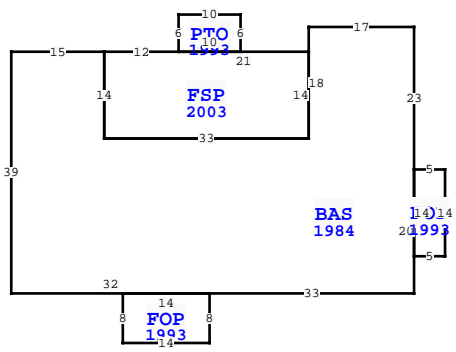
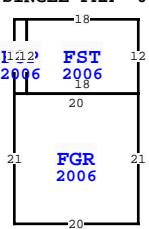

WAKULLA COUNTY PROPERTY			
VALUATION SUMMARY			PAGE 1 of 1
VALUATION BY			STANDARD
Tax Group: 3	Tax Dist:		
BUILDING MARKET VALUE			200,394
TOTAL MARKET OB/XF VALUE			950
TOTAL LAND VALUE - MARKET			13,125
TOTAL MARKET VALUE			214,469
SOH/AGL Deduction			0
ASSESSED VALUE			214,469
TOTAL EXEMPTION VALUE			0
BASE TAXABLE VALUE			214,469
TOTAL JUST VALUE			214,469
NCON VALUE			0
INCOME VALUE			
PREVIOUS YEAR MKT VALUE			217,665
FR 5YR CK NC			
COA RQSTED BY EATON BERNARD & BRENDA			
INCR EYB 1984-1986 PRMT OB21-000333			
5 YR PRCL CK, CHG RCVR. DEL XFOB LN 5,6			
PERMIT NUM	DESCRIPTION	AMT	ISSUED
21000333	MECH-CO	0	06/23/2021
15000507	RE-ROOF	0	06/05/2015
SALES DATA			
OFF RECORD Number	DATE	TYPE INST	Q / V / RSN CD SALE PRICE
0788/0748	3/12/2009	WD Q	I 01 130,000
GRANTOR: MCDONALD CARL K & ROS			
GRANTEE: EATON BERNARD M JR			
0154/0444	6/02/1989	WD U	I 15,000
GRANTOR:			
GRANTEE:			
BUILDING NOTES			
BUILDING DIMENSIONS			
BAS=[YR=1984] W17 S18 W33 N14 FSP=[YR=2003] S14 E33 N14 W21			
PTO=[YR=1993] E10 N6 W10 S6\$ W12\$ W15 PTR=N25 FGR=[YR=2006]			
N21 W20 FOP=[YR=2006] E2 N12 FST=[YR=2006] S12 E18 N12 W18\$			
W2 S12\$ S21 E20\$ S25\$ S39 E32 FOP=[YR=1993] W14 S8 E14 N8\$			
E33 N20 FOP=[YR=1993] S14 E5 N14 W5\$ N23\$.			

EXTRA FEATURES																
L N	OB/XF CODE	DESCRIPTION	BLD CAP	L	W	UNITS	UT	Adj R	ADJ UNIT PRICE	ORIG COND	YEAR ON	YEAR ACTUAL	Q	% COND	OB/XF MKT VALUE	NOTES
1	0140	FIRE PLACE	0	0	0	1.00	UT	1,900.00	1,900.00	100	1993	1993	3	50	950	

LAND DESCRIPTION													TOTAL OB/XF												
L N	USE CODE	CLS	LAND USE DESCRIPTION	CAP	R D	LOC ZONE	FRONT	DEPTH	TOT LND UTS	UNIT TYPE	D T	DPH FACT	% COND	TOT ADJ	UNIT PRICE	ADJ UNIT PRICE	LAND VALUE	OTHER ADJUSTMENTS AND NOTES	YEAR	DENSITY	DECL	FRZ	YR	CONSRV	
1	000100	C	SFR	0			0.00	0.00	1.75	AC		1.00	1.00	1.00	7,500.00	7,500.00	13,125								