

ELEMENT	CD	CONSTRUCTION
Foundation	04	PILE WOOD 100
Frame	12	WOOD FRAME 100
Exterior Wall	02	CEDAR/CYPR 100
Roof Structur	03	GABLE/HIP 100
Roof Cover	01	MINIMUM 100
Interior Wall	06	CUST PANEL 100
Interior Floor	11	CLAY TILE 50
Interior Floor	12	HARDWOOD 50
Heating Type	04	AIR DUCTED 100
Air Condition	03	CENTRAL 100
Bedrooms		5 100
Bathrooms		4.5 100
Story Height		0 100
Stories	2.	2. 100
Units		0 100

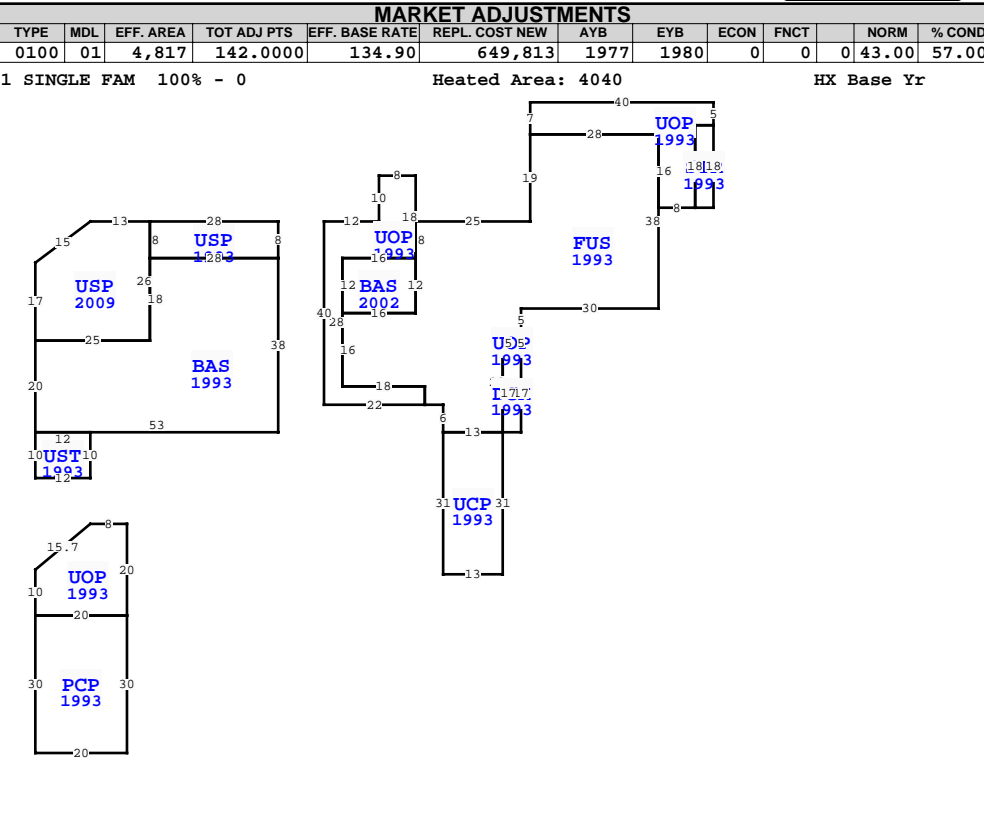

** This building has 14 Sub-Areas

77 FRANK JONES RD, CRAWFORDVILLE

BLD DATE	01/10/2018	MMJT	LGL DATE	
XF DATE	01/10/2018	MMJT	LAND DATE	01/10/2018
INC DATE			AG DATE	

WAKULLA COUNTY PROPERTY		PAGE 1 of 1	3
VALUATION BY		STANDARD	
Tax Group: 3	Tax Dist:		
BUILDING MARKET VALUE			370,393
TOTAL MARKET OB/XF VALUE			5,409
TOTAL LAND VALUE - MARKET			407,707
TOTAL MARKET VALUE			537,548
SOH/AGL Deduction			393,915
ASSESSED VALUE			143,633
TOTAL EXEMPTION VALUE	HX HB WX	55,000	
BASE TAXABLE VALUE			88,633
TOTAL JUST VALUE			783,509
NCON VALUE			0
INCOME VALUE			
PREVIOUS YEAR MKT VALUE			846,205

2024 AG APP RECVD APPRVD
DC OR 1357 P 291 - JOHN MICHAEL CARTER
MM 5YR CK, DEMO XFOBS, CHG XFOB CODE 6/13/23
MAILED THANK YOU LETTER

PERMIT NUM	DESCRIPTION	AMT	ISSUED
OB24-000290	ROOF OVER/METAL-C		04/29/2024
19001529	ELECTRIC	0	12/04/2019
021815	N/A	0	01/29/1997

SALES DATA						
OFF RECORD Number	DATE	TYPE INST	Q / U	V / I	RSN CD	SALE PRICE
0149/0821	2/13/1989	QC	U	V		100

GRANTOR:	
GRANTEE:	
0057/0461	7/01/1977 WD U I 9,000
GRANTOR:	
GRANTEE:	

BUILDING NOTES	
USP=[YR=1993] W28 S8 E28 BAS=[YR=1993] W28 S18 W25 USP=[YR=2009] E25 N26 W13 L12 D9 S17\$ S20 UST=[YR=1993] S10 E12 N10 W12\$ E53 PTR=S20 W33 UOP=[YR=1993] W8 L12 D10 S10 E20 PCP=[YR=1993] W20 S30 E20 N30\$ N20\$ E33 N20\$ PTR=E10 N6 UOP=[YR=1993] E22 N4 W18 N28 E16 BAS=[YR=2002] W16 S12 E16 N12\$ FUS=[YR=1993] S12 W16 S16 E18 S4 E4 S6 E13 DCK=[YR=1993] E4 N17 W4 UOP=[YR=1993] E4 N5 W4 S5\$ S17\$ UCP=[YR=1993] W13 S31 E13 N31\$ N22 E4 N5 E30 N38 W28 UOP=[YR=1993] E28 S16 E8 N18 E4 STR=[YR=1993] W4 S18 E4 N18\$ N5 W40 S7\$ S19 W25 S8\$ N18 W8 S10 W12 S40\$ S6 W10 \$ N38\$ N8\$.	

QUALITY	CD	CONSTRUCTION			
Quality	03	AVERAGE			
DOR CODE	5000	IMPRVD AG RES			
MAP NUM	5	MKT AREA 08			
NEIGHBORHOOD/LOC	000	1.00/			
AREA TYPE	TOTAL GROSS AREA	PCT OF BASE	YEAR	TOT ADJ AREA	SUBAREA MARKET VALUE
BAS	1,564	100	1993	1,564	120,261
BAS	192	100	2002	192	14,764
DCK	68	10	1993	7	538
FUS	2,284	100	1993	2,284	175,624
PCP	600	10	1993	60	4,614
STR	72	10	1993	7	538
UCP	403	20	1993	81	6,228
UOP	20	20	1993	4	308
UOP	340	20	1993	68	5,229
UOP	400	20	1993	80	6,151
TOTALS	7,323			4,817	370,393

EXTRA FEATURES																
L N	OB/XF CODE	DESCRIPTION	BLD CAP	L	W	UNITS	UT	Adj R	ADJ UNIT PRICE	ORIG COND	YEAR ON	YEAR ACTUAL	Q	% COND	OB/XF MKT VALUE	NOTES
4	0940	OPEN SHED	0	100	15	58	SF	4.00	4.00	100	1988	1988	3	20	696	
5	0940	OPEN SHED	0	100	10	18	SF	4.00	4.00	100	1988	1988	3	20	144	
6	0810	UNFINISH S	0	100	12	15	SF	19.00	19.00	100	1988	1988	3	45	1,539	
8	0211	CONCRETE W	0	100	10	12	SF	6.00	6.00	100	1980	1980	3	20	144	
9	0250	ASPHALT AV	0	100	56	34	SF	2.00	2.00	100	1996	1996	3	20	762	
10	0375	WOOD WALK	0	100	46	4	SF	15.00	15.00	100	2007	2007	3	30	828	
11	0350	BOATDOCK A	0	100	15	12	SF	24.00	24.00	100	2007	2007	3	30	1,296	

LAND DESCRIPTION													TOTAL OB/XF												
L N	USE CODE	CLS	LAND USE DESCRIPTION	CAP	R D	LOC ZONE	FRONT	DEPTH	TOT LND UTS	UNIT TYPE	D T	DPH FACT	% COND	TOT ADJ	UNIT PRICE	ADJ UNIT PRICE	LAND VALUE	OTHER ADJUSTMENTS AND NOTES	YEAR	DENSITY	DECL	FRZ	YR	CONSRV	
1	000133	C	SFR LAKE	100			0.00	0.00	1.00	LT		1.00	1.00	1.00	150,000.00	150,000.00	150,000								
2	009500	C	SUBMERGED	0			0.00	0.00	32.57	AC		1.00	1.00	1.00	100.00	100.00	3,257								
3	005500	A	TIMBER 2 PLA	100					34.00	AC		1.00	1.00	1.00	200.00	200.00	6,800								
4	005915	A	HARDWOOD BOT	100					16.89	AC		1.00	1.00	1.00	100.00	100.00	1,689								