

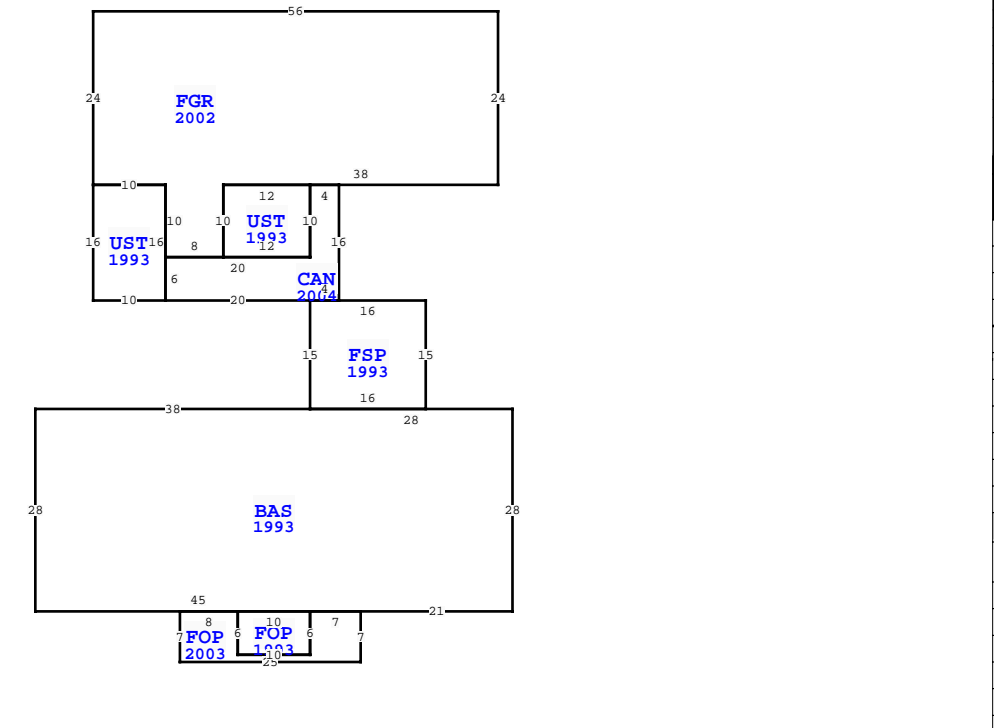

| BUILDING CHARACTERISTICS | | |
|--------------------------|----|----------------|
| ELEMENT | CD | CONSTRUCTION |
| Foundation | 01 | WOOD FRAME 100 |
| Frame | 02 | WOOD FRAME 100 |
| Exterior Wall | 13 | PREFAB PNL 100 |
| Roof Structur | 03 | GABLE/HIP 100 |
| Roof Cover | 13 | GALVALUM 100 |
| Interior Wall | 04 | PLYWOOD 100 |
| Interior Floo | 08 | SHT VINYL 50 |
| Interior Floo | 14 | CARPET 50 |
| Heating Type | 04 | AIR DUCTED 100 |
| Air Condition | 03 | CENTRAL 100 |
| Bedrooms | | 3 100 |
| Bathrooms | | 2 100 |
| Stories | 1. | 1. 100 |
| Class | 00 | N/A 100 |
| Units | | 0 100 |

| MARKET ADJUSTMENTS | | | | | | | | | | | | | |
|--------------------|-----|-----------|-------------|----------------|----------------|------|------|------|------|-------|--------|--|--|
| TYPE | MDL | EFF. AREA | TOT ADJ PTS | EFF. BASE RATE | REPL. COST NEW | AYB | EYB | ECON | FNCT | NORM | % COND | | |
| 0200 | 02 | 3,045 | 99.4500 | 69.62 | 211,993 | 1990 | 1990 | 0 | 0 | 53.00 | 47.00 | | |



| Quality | 08 | FAIR | | | |
|------------------|------------------|-------------|------|--------------|----------------------|
| DOR CODE | 0200 MOBILE HOME | | | | |
| MAP NUM | 4 | MKT AREA 04 | | | |
| NEIGHBORHOOD/LOC | 160.00 | 1.00/ | | | |
| AREA TYPE | TOTAL GROSS AREA | PCT OF BASE | YEAR | TOT ADJ AREA | SUBAREA MARKET VALUE |
| BAS | 1,848 | 100 | 1993 | 1,848 | 60,469 |
| CAN | 184 | 30 | 2004 | 55 | 1,800 |
| FGR | 1,424 | 55 | 2002 | 783 | 25,621 |
| FOP | 60 | 35 | 1993 | 21 | 687 |
| FOP | 115 | 35 | 2003 | 40 | 1,309 |
| FSP | 240 | 60 | 1993 | 144 | 4,712 |
| UST | 120 | 55 | 1993 | 66 | 2,160 |
| UST | 160 | 55 | 1993 | 88 | 2,880 |
| TOTALS | 4,151 | | | 3,045 | 99,637 |

| WAKULLA COUNTY PROPERTY | | | |
|---------------------------|-----------|--|-------------|
| VALUATION SUMMARY | | | PAGE 1 of 1 |
| VALUATION BY | | | STANDARD |
| Tax Group: 3 | Tax Dist: | | |
| BUILDING MARKET VALUE | | | 99,637 |
| TOTAL MARKET OB/XF VALUE | | | 2,006 |
| TOTAL LAND VALUE - MARKET | | | 10,000 |
| TOTAL MARKET VALUE | | | 111,643 |
| SOH/AGL Deduction | | | 81,419 |
| ASSESSED VALUE | | | 30,224 |
| TOTAL EXEMPTION VALUE | HX HB | | 25,000 |
| BASE TAXABLE VALUE | | | 5,224 |
| TOTAL JUST VALUE | | | 111,643 |
| NCON VALUE | | | 0 |
| INCOME VALUE | | | |
| PREVIOUS YEAR MKT VALUE | | | 78,399 |

| LN 4 | 5 YR PRCL CH, CHG DIM XFOB LN 1 & 2, DEL XFOB | | |
|--|---|-----|--------|
| AS PHY ADDR. RMLD RNWL CARD | | | |
| 2016 HX RNWL CARD RTN BY PO W/ FWD ADDR-SAME | | | |
| PERMIT NUM | DESCRIPTION | AMT | ISSUED |
| | | | |
| | | | |
| | | | |

| SALES DATA | | | | | | |
|------------------------------|------------|-----------|-------|-------|--------|------------|
| OFF RECORD Number | DATE | TYPE INST | Q / U | V / I | RSN CD | SALE PRICE |
| 0887/0143 | 8/07/2012 | WD | U | I | 40 | 70,000 |
| GRANTOR: RYALL BETTY C | | | | | | |
| GRANTEE: BARWICK CHRIS E & S | | | | | | |
| 0168/0821 | 11/26/1990 | WD | U | V | | 5,000 |
| GRANTOR: | | | | | | |
| GRANTEE: | | | | | | |

| EXTRA FEATURES | | | | | | | | | | | | | | | | |
|----------------|------------|-------------|---------|-----|----|-------|----|-------|----------------|-----------|---------|-------------|---|--------|-----------------|-------|
| L N | OB/XF CODE | DESCRIPTION | BLD CAP | L | W | UNITS | UT | Adj R | ADJ UNIT PRICE | ORIG COND | YEAR ON | YEAR ACTUAL | Q | % COND | OB/XF MKT VALUE | NOTES |
| 1 | 0055 | PORTABLE C | 0 | 100 | 12 | 18 | | 3.00 | 3.00 | 100 | 2002 | 2002 | 3 | 20 | 151 | |
| 2 | 0210 | CONCRETE D | 0 | 100 | 12 | 14 | | 6.00 | 6.00 | 100 | 2004 | 2004 | 3 | 23 | 348 | |
| 3 | 0080 | 4' CHAINLI | 0 | 100 | 0 | 0 | | 13.00 | 13.00 | 100 | 2012 | 2012 | 3 | 52 | 1,507 | |

| | | | | | | | | | | | | | | | | |
|-----------------------|--|--|--|--|--|--|--|--|--|--|----------|------------|------|-----------|------------|------|
| 153 TOWER RD, PANACEA | | | | | | | | | | | BLD DATE | 02/07/2019 | MMAK | LGL DATE | | |
| | | | | | | | | | | | XF DATE | 02/07/2019 | MMAK | LAND DATE | 02/07/2019 | MMAK |
| | | | | | | | | | | | INC DATE | | | AG DATE | | |

| BUILDING NOTES | | | | | | | | | | |
|----------------|--|--|--|--|--|--|--|--|--|--|
| | | | | | | | | | | |

| BUILDING DIMENSIONS | | | | | | | | | | |
|--|--|--|--|--|--|--|--|--|--|--|
| BAS=[YR=1993] W28 FSP=[YR=1993] E16 N15 W16 CAN=[YR=2004] E4 N16 W4 S10 UST=[YR=1993] N10 W12 S10 E12\$ W20 S6 UST=[YR=1993] N16 W10 FGR=[YR=2002] E10 S10 E8 N10 E38 N24 W56 S24\$ S16 E10\$ E20\$ S15\$ W38 S28 E45 FOP=[YR=2003] W7 S6 W10 N6 FOP=[YR=1993] S6 E10 N6 W10\$ W8 S7 E25 N7\$ E21 N28\$. | | | | | | | | | | |

| LAND DESCRIPTION | | | | | | | | | | | | | | | | | | | | | | | | |
|------------------|----------|-----|----------------------|-----|-----|----------|-------|-------|-------------|-----------|-----|-----------|--------|---------|------------|----------------|------------|-----------------------------|------|---------|------|-----|----|--------|
| L N | USE CODE | CLS | LAND USE DESCRIPTION | CAP | R D | LOC ZONE | FRONT | DEPTH | TOT LND UTS | UNIT TYPE | D T | DPHT FACT | % COND | TOT ADJ | UNIT PRICE | ADJ UNIT PRICE | LAND VALUE | OTHER ADJUSTMENTS AND NOTES | YEAR | DENSITY | DECL | FRZ | YR | CONSRV |
| 1 | 000201 | C | MH | 100 | | | 0.00 | 0.00 | 1.00 | LT | | 1.00 | 1.00 | 1.00 | 10,000.00 | 10,000.00 | 10,000 | | | | | | | |