

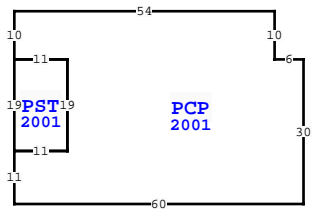

ELEMENT		CD	CONSTRUCTION
Foundation	05	PILE CONCR	100
Frame	02	WOOD FRAME	100
Exterior Wall	30	VINYL	100
Roof Structur	03	GABLE/HIP	100
Roof Cover	12	MODULAR MT	100
Interior Wall	05	DRYWALL	100
Interior Floor	08	SHT VINYL	50
Interior Floor	14	CARPET	50
Heating Type	04	AIR DUCTED	100
Air Condition	03	CENTRAL	100
Bedrooms		3	100
Bathrooms		2	100
Story Height		0	100
Stories	1.	1.	100
Units		0	100
Quality	03	AVERAGE	
DOR CODE	0100	SINGLE FAMILY	
MAP NUM	1	MKT AREA	09
NEIGHBORHOOD/LOC	90.00	1.00/	

MARKET ADJUSTMENTS												
TYPE	MDL	EFF. AREA	TOT ADJ PTS	EFF. BASE RATE	REPL. COST NEW	AYB	EYB	ECON	FNCT	NORM	% COND	
1	SINGLE FAM	100%	- 2004									
					Heated Area: 2120							
						HX Base Yr 2004						

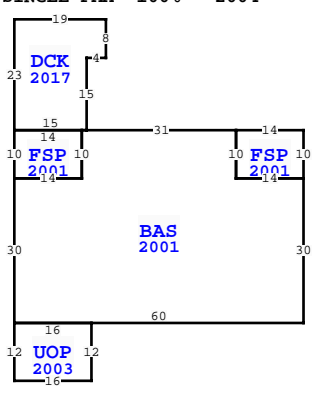

AREA TYPE	TOTAL GROSS AREA	PCT OF BASE	YEAR	TOT ADJ AREA	SUBAREA MARKET VALUE
BAS	2,120	100	2001	2,120	202,649
DCK	377	10	2017	38	3,632
FSP	140	55	2001	77	7,360
FSP	140	55	2001	77	7,360
PCP	2,131	10	2001	213	20,360
PST	209	15	2001	31	2,963
UOP	192	20	2003	38	3,632
TOTALS	5,309			2,594	247,958

335 OLD MAGNOLIA RD, CRAWFORDVILLE

BLD DATE	02/06/2018	RTSR	LGL DATE	
XF DATE	02/06/2018	RTSR	LAND DATE	02/06/2018
INC DATE			AG DATE	

LAND DESCRIPTION													TOTAL OB/XF												
L N	USE CODE	CLS	LAND USE DESCRIPTION	CAP	R D	LOC ZONE	FRONT	DEPTH	TOT LND UTS	UNIT TYPE	D T	DPHT FACT	% COND	TOT ADJ	UNIT PRICE	ADJ UNIT PRICE	LAND VALUE	OTHER ADJUSTMENTS AND NOTES	YEAR	DENSITY	DECL	FRZ	YR	CONSRV	
1	000132	C	SFR RIVER	100		RR1	99.00	300.00	1.00	LT		1.00	1.00	1.00	75,000.00	75,000.00	75,000								

WAKULLA COUNTY PROPERTY			
VALUATION SUMMARY			PAGE 1 of 1
VALUATION BY			STANDARD
Tax Group: 3	Tax Dist:		
BUILDING MARKET VALUE			247,958
TOTAL MARKET OB/XF VALUE			10,635
TOTAL LAND VALUE - MARKET			75,000
TOTAL MARKET VALUE			333,593
SOH/AGL Deduction			124,536
ASSESSED VALUE			209,057
TOTAL EXEMPTION VALUE	HX HB	50,000	
BASE TAXABLE VALUE			159,057
TOTAL JUST VALUE			333,593
NCON VALUE			0
INCOME VALUE			
PREVIOUS YEAR MKT VALUE			322,066

5 YR PRCL CK NC JS			
KEYED ON THE 2/6/18 CARD			
ONLY CHGS, THE OTHER CHANGES WERE PREVIOUSLY			
5 YR PRCL CH, PU XFOB LN 8-10, THOSE WERE THE			
PERMIT NUM	DESCRIPTION	AMT	ISSUED
17001150	DECK	0	09/05/2017
026737	HSE	0	07/05/2000

SALES DATA						
OFF RECORD Number	DATE	TYPE INST	Q U	V I	RSN CD	SALE PRICE
0310/0026	9/30/1997	WD Q	Q	I		57,500

GRANTOR: THIGPEN WESLEY H & RU  
 GRANTEE:

BUILDING NOTES												

BUILDING DIMENSIONS												
FSP=[YR=2001] W14 S10 E14 BAS=[YR=2001] W14 N10 W31 DCK=[YR=2017] N15 E4 N8 W19 S23 E15\$ W1 FSP=[YR=2001] W14 S10 E14 N10\$ S10 W14 S30 UOP=[YR=2003] S12 PTR=S20 PCP=[YR=2001] S10 PST=[YR=2001] S19 E11 N19 W11\$ E11 S19 W11 S11 E60 N30 W6 N10 W54\$ N20\$ E16 N12 W16\$ E60 N30 \$ N10\$. .												