

ELEMENT		CD		CONSTRUCTION	
Foundation	02	CONCR	SLAB	100	
Frame	02	WOOD	FRAME	100	
Exterior Wall	19	COMMON	BRK	100	
Roof Structur	03	GABLE/HIP	100		
Roof Cover	03	COMP	SHNGL	100	
Interior Wall	05	DRYWALL	100		
Interior Floor	11	CLAY	TILE	50	
Interior Floor	14	CARPET	50		
Heating Type	04	AIR	DUCTED	100	
Air Condition	03	CENTRAL	100		
Bedrooms				4	100
Bathrooms				2	100
Story Height				0	100
Stories	1.			1.	100
Units				0	100
Quality	03	AVERAGE			
DOR CODE	0100	SINGLE FAMILY			
MAP NUM	1	MKT AREA		11	
NEIGHBORHOOD/LOC	000	1.00/			
AREA TYPE	TOTAL GROSS AREA	PCT OF BASE	YEAR	TOT ADJ AREA	SUBAREA MARKET VALUE
BAS	2,066	100	2015	2,066	219,381
FGR	552	50	2015	276	29,308
FOP	186	30	2015	56	5,947
FOP	203	30	2015	61	6,478
PTO	348	5	2015	17	1,805
TOTALS	3,355			2,476	262,918

MARKET ADJUSTMENTS											
TYPE	MDL	EFF. AREA	TOT ADJ PTS	EFF. BASE RATE	REPL. COST NEW	AYB	EYB	ECON	FNCT	NORM	% COND
1	SINGLE FAM	100% - 2016									
Heated Area: 2066 HX Base Yr 2016											

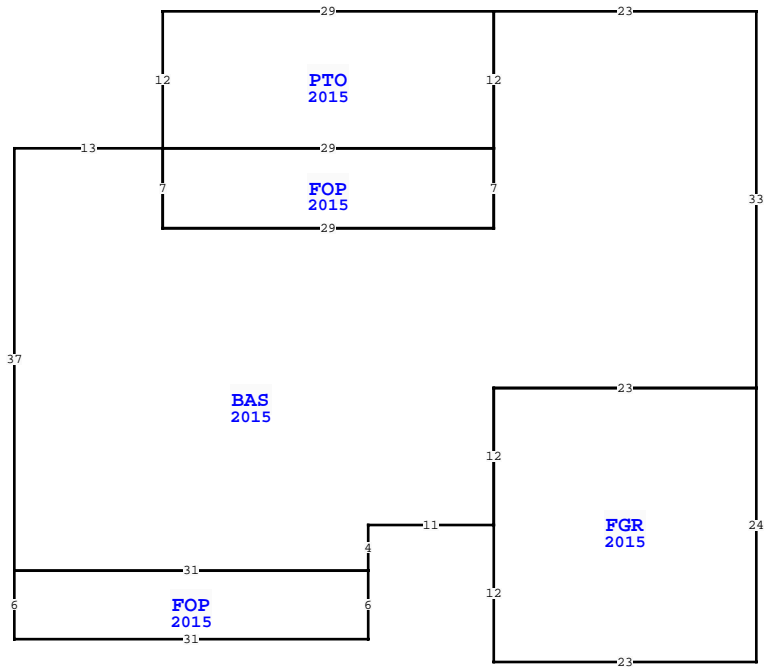

WAKULLA COUNTY PROPERTY			
VALUATION SUMMARY			PAGE 1 of 1
VALUATION BY			STANDARD
Tax Group: 3	Tax Dist:		
BUILDING MARKET VALUE			262,918
TOTAL MARKET OB/XF VALUE			27,421
TOTAL LAND VALUE - MARKET			50,100
TOTAL MARKET VALUE			340,439
SOH/AGL Deduction			94,648
ASSESSED VALUE			245,791
TOTAL EXEMPTION VALUE	HX HB SX		100,000
BASE TAXABLE VALUE			145,791
TOTAL JUST VALUE			340,439
NCON VALUE			0
INCOME VALUE			
PREVIOUS YEAR MKT VALUE			332,091
5 YR PRCL CH, PU XFOB LNS 4-6			
ADD CHG PER USPS FORM 3547			
PRCL:0:1: SOH PORTED FROM LEON FOR 2016 FOR KIMBRE			
5 YR PRCL CH, PU SFD & XFOB LN 1-3			
PERMIT NUM	DESCRIPTION	AMT	ISSUED
2014750	SFD-CO	0	09/11/2014
SALES DATA			
OFF RECORD Number	DATE	TYPE INST	Q / V / RSN CD SALE PRICE
0946/0450	7/06/2014	WD Q	V 01 45,000
GRANTOR: BASS ANDREW D & JOANN			
GRANTEE: KIMBREL GEORGE F II			
BUILDING NOTES			
BUILDING DIMENSIONS			
BAS=[YR=2015] W23 PTO=[YR=2015] W29 S12 E29 N12\$ S12 FOP=[YR=2015] W29 S7 E29 N7\$ S7 W29 N7 W13 S37 FOP=[YR=2015] S6 E31 N6 W31\$ E31 N4 E11 FGR=[YR=2015] S12 E23 N24 W23 S12\$ N12 E23 N33\$.			

EXTRA FEATURES																
L N	OB/XF CODE	DESCRIPTION	BLD CAP	L	W	UNITS	UT	Adj R	ADJ UNIT PRICE	ORIG COND	YEAR ON	YEAR ACTUAL	Q	% COND	OB/XF MKT VALUE	NOTES
1	0210	CONCRETE D	0	100	20	18			6.00	100	2015	2015	3	67	1,447	
2	0211	CONCRETE W	0	100	0	0			6.00	100	2015	2015	3	67	1,001	
3	0130	FIRE PLACE	0	100	0	0			1,300.00	100	2015	2015	3	84	1,092	
4	0080	4' CHAINLI	0	100	0	0			13.00	100	2016	2016	3	72	2,574	
5	0025	BARN, POLE	0	100	60	30			12.50	100	2020	2020	3	89	20,025	
6	0210	CONCRETE D	0	100	24	10			6.00	100	2020	2020	3	89	1,282	
TOTALS															27,421	

LAND DESCRIPTION										TOTAL OB/XF														
L N	USE CODE	CLS	LAND USE DESCRIPTION	CAP	R D	LOC ZONE	FRONT	DEPTH	TOT LND UTS	UNIT TYPE	D T	DPH FACT	% COND	TOT ADJ	UNIT PRICE	ADJ UNIT PRICE	LAND VALUE	OTHER ADJUSTMENTS AND NOTES	YEAR	DENSITY	DECL	FRZ	YR	CONSRV
1	000100	C	SFR				0.00	0.00	5.01	AC		1.00	1.00	1.00	10,000.00	10,000.00	50,100							