

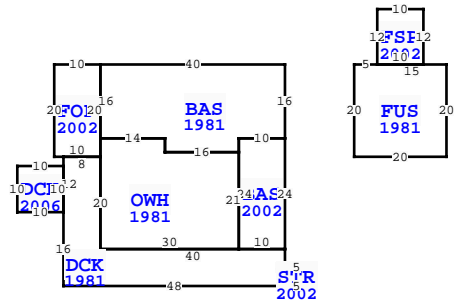

| BUILDING CHARACTERISTICS | | |
|--------------------------|------------------|----------------|
| ELEMENT | CD | CONSTRUCTION |
| Foundation | 03 | CONCR STEM 100 |
| Frame | 02 | WOOD FRAME 100 |
| Exterior Wall | 06 | BD/BATTEN 100 |
| Roof Structur | 03 | GABLE/HIP 100 |
| Roof Cover | 03 | COMP SHNGL 80 |
| Roof Cover | 13 | GALVALUM 20 |
| Interior Wall | 05 | DRYWALL 50 |
| Interior Wall | 06 | CUST PANEL 50 |
| Interior Floo | 12 | HARDWOOD 100 |
| Heating Type | 04 | AIR DUCTED 100 |
| Air Condition | 03 | CENTRAL 100 |
| Bedrooms | | 3 100 |
| Bathrooms | | 3 100 |
| Story Height | | 0 100 |
| Stories | 1.5 | 1.5 100 |
| Units | | 0 100 |
| Quality | 07 | GOOD |
| DOR CODE | 5000 | IMPRVD AG RES |
| MAP NUM | 5 | MKT AREA 02 |
| NEIGHBORHOOD/LOC | 53.00 | 1.00/ |
| AREA TYPE | TOTAL GROSS AREA | PCT OF BASE |
| BAS | 688 | 100 |
| BAS | 240 | 100 |
| DCK | 544 | 10 |
| DCK | 100 | 10 |
| FOP | 200 | 30 |
| FSP | 120 | 55 |
| FUS | 400 | 100 |
| OWH | 672 | 100 |
| STR | 20 | 10 |
| USP | 137 | 40 |
| TOTALS | 3,121 | |

| MARKET ADJUSTMENTS | | | | | | | | | | | |
|--------------------|------------|-----------|-------------|----------------|----------------|------|------|-----------------|------|-------|--------|
| TYPE | MDL | EFF. AREA | TOT ADJ PTS | EFF. BASE RATE | REPL. COST NEW | AYB | EYB | ECON | FNCT | NORM | % COND |
| 1 | SINGLE FAM | 100% | - 2017 | | 295,818 | 1981 | 2010 | 0 | 0 | 13.00 | 87.00 |
| | | | | Heated Area: | 2000 | | | HX Base Yr 2017 | | | |

| WAKULLA COUNTY PROPERTY | | | |
|---|-------------|-------------|------------|
| VALUATION SUMMARY | | PAGE 1 of 2 | |
| VALUATION BY | | STANDARD | |
| Tax Group: 3 | | Tax Dist: | |
| BUILDING MARKET VALUE | | 257,362 | |
| TOTAL MARKET OB/XF VALUE | | 13,022 | |
| TOTAL LAND VALUE - MARKET | | 94,775 | |
| TOTAL MARKET VALUE | | 322,324 | |
| SOH/AGL Deduction | | 207,499 | |
| ASSESSED VALUE | | 114,825 | |
| TOTAL EXEMPTION VALUE | | 50,000 | |
| BASE TAXABLE VALUE | | 64,825 | |
| TOTAL JUST VALUE | | 365,159 | |
| NCON VALUE | | 0 | |
| INCOME VALUE | | 0 | |
| PREVIOUS YEAR MKT VALUE | | 323,100 | |
| MM 5YR CK, PU XFOB 1/12/2023 | | | |
| 2022 AG RENEWAL RECD | | | |
| 2021 AG RENEW W/O RETURN CARD | | | |
| INSPECTION & OWNERS VISIT IN OFFICE W/J.BURKE | | | |
| PERMIT NUM | DESCRIPTION | AMT | ISSUED |
| 15000344 | DEMO | 0 | 04/22/2015 |
| 15000342 | RE-ROOF | 0 | 04/22/2015 |
| 15000223 | RE-ROOF | 0 | 03/25/2015 |



| SALES DATA | | | | | | |
|--------------------------------|-----------|-----------|-------|-------|--------|------------|
| OFF RECORD Number | DATE | TYPE INST | Q / U | V / I | RSN CD | SALE PRICE |
| 0982/0566 | 8/19/2015 | WD | U | I | 12 | 178,000 |
| GRANTOR: US BANK NATIONAL ASSO | | | | | | |
| GRANTEE: MORGAN MATTHEW B & | | | | | | |
| 0945/0336 | 6/12/2014 | CT | U | I | 11 | 100 |
| GRANTOR: CLERK OF COURT / NELS | | | | | | |
| GRANTEE: US BANK NATIONAL AS | | | | | | |

| EXTRA FEATURES | | | | | | | | | | | |
|----------------|------------|-------------|---------|----|-----|--------|----|----------|----------------|-----------|---------|
| L N | OB/XF CODE | DESCRIPTION | BLD CAP | L | W | UNITS | UT | Adj R | ADJ UNIT PRICE | ORIG COND | YEAR ON |
| 1 | 0375 | WOOD WALK | 0 100 | 3 | 125 | 375.00 | SF | 15.00 | 15.00 | 100 | 1993 |
| 2 | 0130 | FIRE PLACE | 0 100 | 0 | 0 | 1.00 | UT | 1,300.00 | 1,300.00 | 100 | 2002 |
| 3 | 0700 | PORT BLDG | 0 100 | 10 | 6 | 60.00 | SF | 8.00 | 8.00 | 100 | 2002 |
| 4 | 0520 | WORK SHOP | 0 100 | 35 | 24 | 840.00 | SF | 12.00 | 12.00 | 100 | 2002 |
| 5 | 0040 | CARPOT FI | 0 100 | 20 | 16 | 320.00 | SF | 12.00 | 12.00 | 100 | 1993 |
| 6 | 0770 | PUMP HOUSE | 0 100 | 4 | 4 | 16.00 | SF | 5.00 | 5.00 | 100 | 2003 |
| 7 | 0350 | BOATDOCK A | 0 100 | 16 | 8 | 128.00 | SF | 24.00 | 24.00 | 100 | 2006 |
| 8 | 0060 | DECK WOOD | 0 100 | 12 | 5 | 60.00 | SF | 5.00 | 5.00 | 100 | 2006 |
| 9 | 0055 | PORTABLE C | 0 100 | 25 | 24 | 600.00 | SF | 3.00 | 3.00 | 100 | 2017 |
| 10 | 0055 | PORTABLE C | 0 100 | 20 | 18 | 360.00 | SF | 3.00 | 3.00 | 100 | 2017 |

| TOTAL OB/XF | | | | | | | | | | | |
|-------------|------------|------|-----------|------------|------|--|--|--|--|--|--|
| 9,219 | | | | | | | | | | | |
| BLD DATE | 07/18/2018 | MMJT | LGL DATE | 07/18/2018 | MMJT | | | | | | |
| XF DATE | 07/18/2018 | MMJT | LAND DATE | 07/18/2018 | MMJT | | | | | | |
| INC DATE | | | AG DATE | | | | | | | | |

| BUILDING NOTES | | | | | | | | | | | |
|----------------|--|--|--|--|--|--|--|--|--|--|--|
|----------------|--|--|--|--|--|--|--|--|--|--|--|

| BUILDING DIMENSIONS | | | | | | | | | | | |
|--|--|--|--|--|--|--|--|--|--|--|--|
| BAS=[YR=1981] W40 S16 E14 S3 E16 N3 E10 BAS=[YR=2002] W10 S24 E10 DCK=[YR=1981] W40 N20 OWH=[YR=1981] S20 E30 N21 W16 N3 W14 S4\$ FOP=[YR=2002] N20 W10 PTR=W30 N80 USP=[YR=2002] E5 R4 U4 N5 U4 L4 W5 L4 D4 S5 D4 R4 \$ S80 E30 \$ S20 E10\$ W8 S12 DCK=[YR=2006] N10 W10 S10 E10\$ S16 E48 STR=[YR=2002] E5 N4 W5 S4\$ N24\$ N16\$ PTR=E15 FUS=[YR=1981] S20 E20 N20 W15 FSP=[YR=2002] E10 N12 W10 S12\$ W5\$ W15\$. | | | | | | | | | | | |

| LAND DESCRIPTION | | | | | | | | | | | |
|------------------|----------|-----|----------------------|-----|-----|----------|-------|-------|-------------|-----------|------|
| L N | USE CODE | CLS | LAND USE DESCRIPTION | CAP | R D | LOC ZONE | FRONT | DEPTH | TOT LND UTS | UNIT TYPE | D T |
| 1 | 000132 | C | SFR RIVER | 100 | | | 0.00 | 0.00 | 1.00 | AC | 1.00 |
| 2 | 005970 | A | TIMBER MIX 1 | 0 | | | 0.00 | 0.00 | 5.97 | AC | 1.00 |

