

ANDREWS PH 2 LOT 1 2.85 AC
 FKA BREAKAWAY ACRES LOT 6
 OR 88 P 424 OR 102 P 453

VICK ROBERT D/MELTON JEAN H
 130 SANDERS CEMETERY RD
 SOPCHOPPY, FL 32358

2024

34-5S-03W-150-01263-006

ELEMENT	CD	CONSTRUCTION
Foundation	04	PILE WOOD 100
Frame	12	WOOD FRAME 100
Exterior Wall	02	CEDAR/CYPR 100
Roof Structur	03	GABLE/HIP 100
Roof Cover	03	COMP SHNGL 100
Interior Wall	05	DRYWALL 50
Interior Wall	06	CUST PANEL 50
Interior Floor	12	HARDWOOD 70
Interior Floor	14	CARPET 30
Heating Type	04	AIR DUCTED 100
Air Condition	03	CENTRAL 100
Bedrooms		3 100
Bathrooms		2 100
Story Height		0 100
Stories	1.	1. 100
Units		0 100

MARKET ADJUSTMENTS													
TYPE	MDL	EFF. AREA	TOT ADJ PTS	EFF. BASE RATE	REPL. COST NEW	AYB	EYB	ECON	FNCT	NORM	% COND		
1	SINGLE FAM	100%	- 2017		377,532	1987	1987	0	0	36.00	64.00	Heated Area: 1797 HX Base Yr 2017	

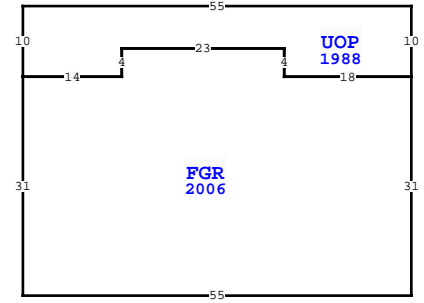
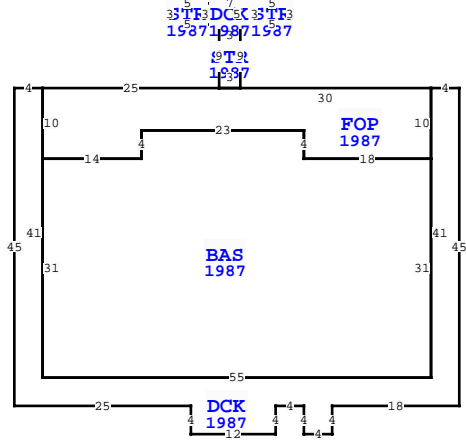

AREA TYPE	TOTAL GROSS AREA	PCT OF BASE	YEAR	TOT ADJ AREA	SUBAREA MARKET VALUE
BAS	1,797	100	1987	1,797	144,876
DCK	21	10	1987	2	161
DCK	644	10	1987	64	5,160
FGR	1,797	50	2006	898	72,397
FOP	458	30	1987	137	11,045
STR	15	10	1987	2	161
STR	15	10	1987	2	161
STR	27	10	1987	3	242
UOP	458	20	1988	92	7,417
TOTALS	5,232			2,997	241,620

130 SANDERS CEMETERY RD, SOPCHOPPY

BLD DATE	09/05/2019	MMAK	LGL DATE	
XF DATE	12/13/2016	MMAK	LAND DATE	09/05/2019
INC DATE			AG DATE	

L N	OB/XF CODE	DESCRIPTION	BLD	CAP	L	W	UNITS	UT	Adj R	ADJ UNIT PRICE	ORIG COND	YEAR ON	YEAR ACTUAL	Q	% COND	OB/XF MKT VALUE	NOTES
1	0350	BOATDOCK A	0	100	16	20	320.00	SF	24.00	24.00	100	2002	2002	3	20	1,536	
2	0140	FIRE PLACE	0	100	0	0	1.00	UT	1,900.00	1,900.00	100	1987	1987	3	44	836	
3	0940	OPEN SHED	0	100	12	10	120.00	SF	4.00	4.00	100	2002	2002	3	20	96	
4	0820	SEAWALL,WO	0	100	0	0	200.00	LF	34.00	34.00	100	2002	2002	3	20	1,360	
5	0500	WORK SHOP	0	100	48	32	1,536.00	SF	15.00	15.00	100	2002	2002	3	20	4,608	
6	0211	CONCRETE W	0	100	214	3	642.00	SF	6.00	6.00	100	2002	2002	3	20	770	
7	0210	CONCRETE D	0	100	13	5	65.00	SF	6.00	6.00	100	2006	2006	3	27	105	
8	0371	FLOATING D	0	100	33	10	330.00	SF	20.00	20.00	100	2008	2008	3	34	2,244	
9	0730	FINISHED O	0	100	8	7	56.00	SF	14.00	14.00	100	2008	2008	3	70	549	
10	0335	ALUMINUM W	0	100	16	3	48.00	SF	17.00	17.00	100	2008	2008	3	34	277	

TOTAL OB/XF 12,381

LAND DESCRIPTION																	
L N	USE CODE	CLS	LAND USE DESCRIPTION	CAP	R D	LOC ZONE	FRONT	DEPTH	TOT LND UTS	UNIT TYPE	D T	DPHT FACT	% COND	TOT ADJ	UNIT PRICE	ADJ UNIT PRICE	LAND VALUE
1	000132	C	SFR RIVER	100			0.00	0.00	1.00	UT		1.00	1.00	1.25	95,000.00	118,750.00	118,750

WAKULLA COUNTY PROPERTY				PAGE 1 of 2	3
VALUATION SUMMARY					
VALUATION BY				STANDARD	
Tax Group: 3				Tax Dist:	
BUILDING MARKET VALUE				241,620	
TOTAL MARKET OB/XF VALUE				17,590	
TOTAL LAND VALUE - MARKET				118,750	
TOTAL MARKET VALUE				377,960	
SOH/AGL Deduction				84,729	
ASSESSED VALUE				293,231	
TOTAL EXEMPTION VALUE				HX HB 50,000	
BASE TAXABLE VALUE				243,231	
TOTAL JUST VALUE				377,960	
NCON VALUE				0	
INCOME VALUE					
PREVIOUS YEAR MKT VALUE				383,055	
14					
5 YR PRCL CH, CHG INT & FLOR, PU XFOB LN 13 & SOH PORTED FROM GADSDEN 2017/ MELTON					
DIMENS XFOB LN 1					
PERMIT NUM	DESCRIPTION	AMT	ISSUED		

SALES DATA						
OFF RECORD Number	DATE	TYPE INST	Q U	V I	RSN CD	SALE PRICE
1024/0457	1/27/2017	QC	U	I	11	37,500
GRANTOR: ANDREWS NELSON & KATH						
GRANTEE: VICK ROBERT D & MEL						
0975/0686	7/13/2015	WD	Q	I	01	295,000
GRANTOR: ANDREWS NELSON & KATH						
GRANTEE: VICK ROBERT D & MEL						

BUILDING NOTES																	
DCK=[YR=1987] W4 S41 W55 N41 POP=[YR=1987] S10 E14 N4 E23 S4 E18 BAS=[YR=1987] W18 N4 W23 S4 W14 S31 E55 N31\$ N10 W30 STR=[YR=1987] E3 N9 W3 DCK=[YR=1987] E5 N3 STR=[YR=1987] S3 E5 N3 W5\$ W7 S3 STR=[YR=1987] N3 W5 S3 E5\$ E2\$ S9\$ W25\$ W4 S45 E25 S4 E12 N4 E4 S4 E4 N4 E18 PTR=E10 N4 FGR=[YR=2006] E55 N31 W18 N4 W23 S4 W14 UOP=[YR=1988] E14 N4 E23 S4 E18 N10 W55 S10\$ S31\$ S4 W10\$ N45\$.																	

BUILDING DIMENSIONS																	
DCK=[YR=1987] W4 S41 W55 N41 POP=[YR=1987] S10 E14 N4 E23 S4 E18 BAS=[YR=1987] W18 N4 W23 S4 W14 S31 E55 N31\$ N10 W30 STR=[YR=1987] E3 N9 W3 DCK=[YR=1987] E5 N3 STR=[YR=1987] S3 E5 N3 W5\$ W7 S3 STR=[YR=1987] N3 W5 S3 E5\$ E2\$ S9\$ W25\$ W4 S45 E25 S4 E12 N4 E4 S4 E4 N4 E18 PTR=E10 N4 FGR=[YR=2006] E55 N31 W18 N4 W23 S4 W14 UOP=[YR=1988] E14 N4 E23 S4 E18 N10 W55 S10\$ S31\$ S4 W10\$ N45\$.																	

