

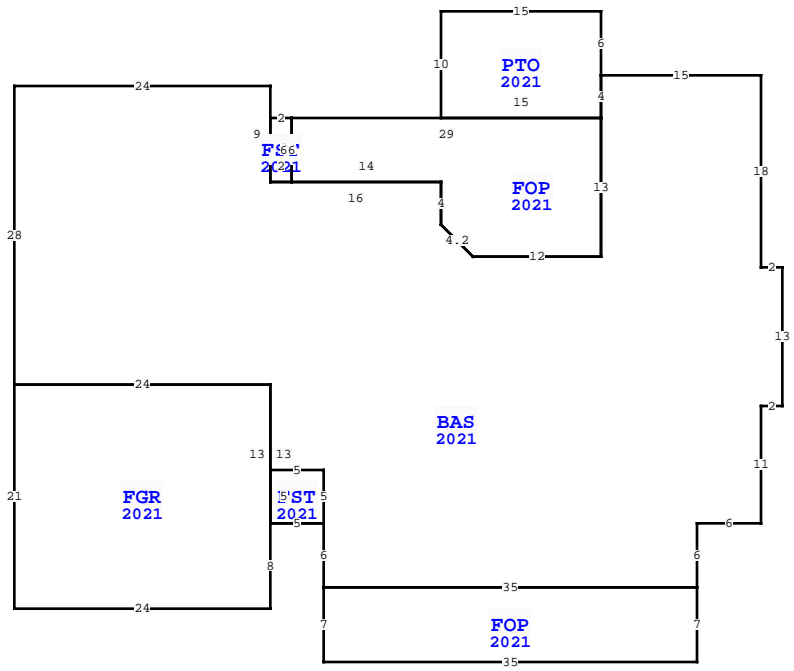

ELEMENT		CD		CONSTRUCTION	
Foundation	02	CONCR	SLAB	100	
Frame	02	WOOD	FRAME	100	
Exterior Wall	11	AVERAGE	90		
Exterior Wall	11	AVERAGE	10		
Roof Structur	03	GABLE/HIP	100		
Roof Cover	03	COMP SHNGL	100		
Interior Wall	05	DRYWALL	100		
Interior Floor	11	CLAY TILE	90		
Interior Floor	14	CARPET	10		
Heating Type	04	AIR DUCTED	100		
Air Condition	03	CENTRAL	100		
Bedrooms		4	100		
Bathrooms		3	100		
Story Height		0	100		
Stories	1.	1.	100		
Units		0	100		
Quality	03	AVERAGE			
DOR CODE	0100	SINGLE FAMILY			
MAP NUM	1	MKT AREA	11		
NEIGHBORHOOD/LOC	246.00	1.00/			
AREA TYPE	TOTAL GROSS AREA	PCT OF BASE	YEAR	TOT ADJ AREA	SUBAREA MARKET VALUE
BAS	2,430	100	2021	2,430	286,196
FGR	504	50	2021	252	29,679
FOP	245	30	2021	74	8,715
FOP	275	30	2021	82	9,658
FST	12	55	2021	7	824
FST	25	55	2021	14	1,649
PTO	150	5	2021	8	942
TOTALS	3,641			2,867	337,665

MARKET ADJUSTMENTS													
TYPE	MDL	EFF. AREA	TOT ADJ PTS	EFF. BASE RATE	REPL. COST NEW	AYB	EYB	ECON	FNCT	NORM	% COND		
1	SINGLE FAM	100%	- 2022									Heated Area: 2430	HX Base Yr 2022



WAKULLA COUNTY PROPERTY			
VALUATION SUMMARY		PAGE 1 of 2	
VALUATION BY		STANDARD	
Tax Group: 3		Tax Dist:	
BUILDING MARKET VALUE		343,862	
TOTAL MARKET OB/XF VALUE		12,911	
TOTAL LAND VALUE - MARKET		75,000	
TOTAL MARKET VALUE		431,773	
SOH/AGL Deduction		0	
ASSESSED VALUE		431,773	
TOTAL EXEMPTION VALUE		HX HB 13 431,773	
BASE TAXABLE VALUE		0	
TOTAL JUST VALUE		431,773	
NCON VALUE		0	
INCOME VALUE		0	
PREVIOUS YEAR MKT VALUE		431,862	
PU SFD, XFOB, POWER 8/05/21, PU BUILDING CARD-2			
5 YR PRCL CH, N/C			
5 YR PRCL CH, N/C			
5 YR PRCL CH - N/C			
PERMIT NUM	DESCRIPTION	AMT	ISSUED
21000831	SHED	0	08/13/2021
21000420	SFD-CO	0	04/27/2021
027068	SHED	0	10/13/2000

SALES DATA						
OFF RECORD Number	DATE	TYPE INST	Q U	V I	RSN CD	SALE PRICE
1227/0635	9/08/2021	WD Q	Q	I	01	474,600
GRANTOR: GOLDEN CONSTRUCTION C						
GRANTEE: BRESETTE RICHARD B						
1197/0783	3/10/2021	WD Q	Q	V	05	335,000
GRANTOR: KENNETH STRATTON KIRT						
GRANTEE: GOLDEN CONSTRUCTION						

EXTRA FEATURES																
L N	OB/XF CODE	DESCRIPTION	BLD CAP	L	W	UNITS	UT	Adj R	ADJ UNIT PRICE	ORIG COND	YEAR ON	YEAR ACTUAL	Q	% COND	OB/XF MKT VALUE	NOTES
1	0625	PORT WD UT	0	100	14	16			6.00	100	2000	2000	3	20	269	
2	0210	CONCRETE D	0	100	0	0			6.00	100	2021	2021	3	93	8,716	
3	0211	CONCRETE W	0	100	54	4			6.00	100	2021	2021	3	93	1,205	
4	0211	CONCRETE W	0	100	9	5			6.00	100	2021	2021	3	93	251	
5	0955	PRIVACY FE	0	100	0	0			15.00	100	2021	2021	3	98	2,470	

BUILDING NOTES													
BLD DATE 09/22/2021 FRFR LGL DATE 09/22/2021 FRFR													
XF DATE 09/22/2021 FRLH LAND DATE 09/22/2021 FRFR													
INC DATE AG DATE													

BUILDING DIMENSIONS													
BAS=[YR=2021] W15 PTO=[YR=2021] N6 W15 S10 E15 N4\$ S4													
FOP=[YR=2021] W29 FST=[YR=2021] W2 S6 E2 N6\$ S6 E14 S4 D3 R3													
E12 N13\$ S13 W12 L3 U3 N4 W16 N9 W24 S28 FGR=[YR=2021] S21													
E24 N8 FST=[YR=2021] E5 N5 W5 S5\$ N13 W24\$ E24 S13 E5 S6													
FOP=[YR=2021] S7 E35 N7 W35\$ E35 N6 E6 N11 E2 N13 W2 N18\$.													

LAND DESCRIPTION														TOTAL OB/XF 12,911										
L N	USE CODE	CLS	LAND USE DESCRIPTION	CAP	R D	LOC ZONE	FRONT	DEPTH	TOT LND UTS	UNIT TYPE	D T	DPH FACT	% COND	TOT ADJ	UNIT PRICE	ADJ UNIT PRICE	LAND VALUE	OTHER ADJUSTMENTS AND NOTES	YEAR	DENSITY	DECL	FRZ	YR	CONSRV
1	000100	C	SFR	100			0.00	0.00	1.00	LT		1.00	1.00	1.00	75,000.00	75,000.00	75,000							

BUILDING CHARACTERISTICS		CONSTRUCTION	
ELEMENT	CD		
Foundation	02	CONCR SLAB	100
Frame	05	STEEL	100
Exterior Wall	27	PREFIN MTL	100
Roof Structur	03	GABLE/HIP	100
Roof Cover	12	MODULAR MT	100
Interior Wall	07	NONE	100
Interior Floo	03	CONC FINSH	100
Heating Type	02	CONVECTION	100
Air Condition	02	WINDOW	100
Story Height	0	0	100
Stories	0	0	100
Units	0	0	100
Quality	03	AVERAGE	
DOR CODE	0100	SINGLE FAMILY	
MAP NUM	1	MKT AREA	11
NEIGHBORHOOD/LOC	246.00	1.00/	
AREA TYPE	TOTAL GROSS AREA	PCT OF BASE	YEAR
UWS	900	25	2021
TOTALS	900	225	6,197

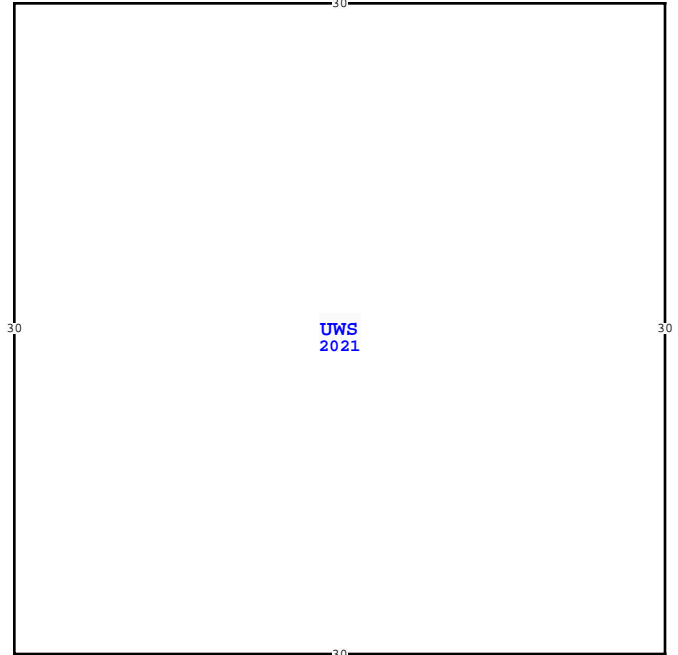
MARKET ADJUSTMENTS																										
TYPE	MDL	EFF. AREA	TOT ADJ PTS	EFF. BASE RATE	REPL. COST NEW	AYB	EYB	ECON	FNCT	NORM	% COND															
2	WKSHP/BARN	100%	- 2022	28.25	6,356	2021	2021	0	0	2.50	97.50															
Heated Area: 0 HX Base Yr 2022																										
																										
<table border="1" style="width: 100%;"> <tr> <td>BLD DATE</td> <td>09/22/2021</td> <td>FRFR</td> <td>LGL DATE</td> <td></td> </tr> <tr> <td>XF DATE</td> <td>09/22/2021</td> <td>FRLH</td> <td>LAND DATE</td> <td>09/22/2021</td> </tr> <tr> <td>INC DATE</td> <td></td> <td></td> <td>AG DATE</td> <td></td> </tr> </table>												BLD DATE	09/22/2021	FRFR	LGL DATE		XF DATE	09/22/2021	FRLH	LAND DATE	09/22/2021	INC DATE			AG DATE	
BLD DATE	09/22/2021	FRFR	LGL DATE																							
XF DATE	09/22/2021	FRLH	LAND DATE	09/22/2021																						
INC DATE			AG DATE																							
17 STRATTONWOOD PL, CRAWFORDVILLE																										

WAKULLA COUNTY PROPERTY				PAGE 2 of 2	3	
VALUATION SUMMARY						
VALUATION BY				STANDARD		
Tax Group: 3				Tax Dist:		
BUILDING MARKET VALUE				343,862		
TOTAL MARKET OB/XF VALUE				12,911		
TOTAL LAND VALUE - MARKET				75,000		
TOTAL MARKET VALUE				431,773		
SOH/AGL Deduction				0		
ASSESSED VALUE				431,773		
TOTAL EXEMPTION VALUE				HX HB 13 431,773		
BASE TAXABLE VALUE				0		
TOTAL JUST VALUE				431,773		
NCON VALUE				0		
INCOME VALUE						
PREVIOUS YEAR MKT VALUE				431,862		
CORRECTED SITE SPELLING						
LAND VAL CHG PER DOR STUDY						
REDUCE AC/COMPARE W/001						
ADD CHG						
PERMIT NUM	DESCRIPTION	AMT	ISSUED			
SALES DATA						
OFF RECORD Number	DATE	TYPE INST	Q / U	V / I	RSN CD	SALE PRICE
1227/0635	9/08/2021	WD Q	Q	I	01	474,600
GRANTOR: GOLDEN CONSTRUCTION C						
GRANTEE: BRESETTE RICHARD B						
1197/0783	3/10/2021	WD Q	Q	V	05	335,000
GRANTOR: KENNETH STRATTON KIRT						
GRANTEE: GOLDEN CONSTRUCTION						
BUILDING NOTES						
BUILDING DIMENSIONS						
UWS=[YR=2021] W30 S30 E30 N30\$.						

EXTRA FEATURES																
L N	OB/XF CODE	DESCRIPTION	BLD CAP	L	W	UNITS	UT	Adj R	ADJ UNIT PRICE	ORIG COND	YEAR ON	YEAR ACTUAL	Q	% COND	OB/XF MKT VALUE	NOTES
17 STRATTONWOOD PL, CRAWFORDVILLE																
TOTALS 900 225 6,197																

LAND DESCRIPTION												TOTAL OB/XF												0				
L N	USE CODE	CLS	LAND USE DESCRIPTION	CAP	R D	LOC ZONE	FRONT	DEPTH	TOT LND UTS	UNIT TYPE	D T	DPH FACT	% COND	TOT ADJ	UNIT PRICE	ADJ UNIT PRICE	LAND VALUE	OTHER ADJUSTMENTS AND NOTES	YEAR	DENSITY	DECL	FRZ	YR	CONSRV				